

≡ Official Monthly Publication of the Society for Information Display

# INFORMATION DISPLAY

October 1987  
Vol. 3, No. 9



**Holography**  
**Graphics processors**  
**3D television**

Non-Profit Organization  
U.S. Postage  
**PAID**  
Phillipsburg, NJ  
Permit No. 187

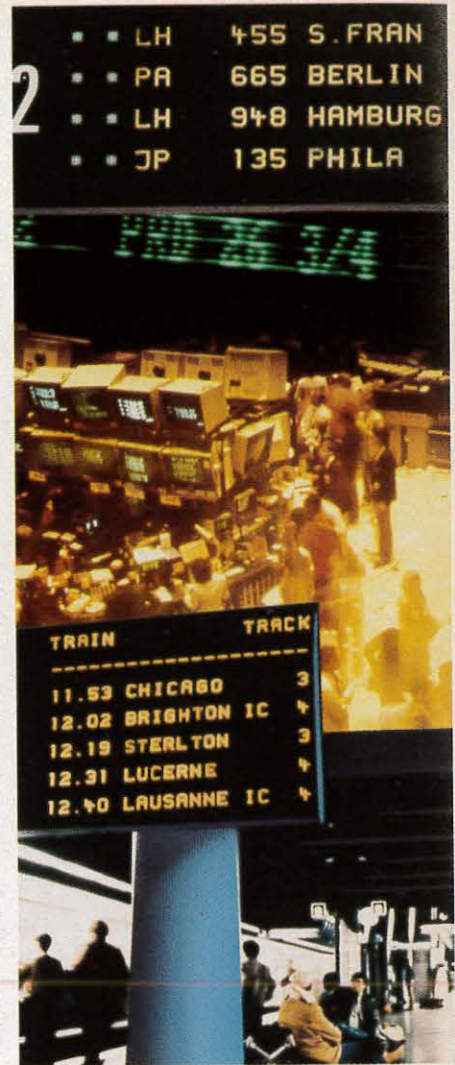

**LCDs from AEG...  
any way you look  
at them,  
they're clearly  
superior**

Engineers throughout the world have specified AEG custom designed LCDs when their display requirements demanded the best technology available. Our displays are highly engineered to perform under the most stringent environmental conditions.

Reliability and long life is provided by our chip-on-glass technology, eliminating the need for interconnecting to a PCB. The result is an LCD only 3mm in thickness that is completely shock and vibration resistant with an operational temperature range of  $-55^{\circ}\text{C}$  to  $+95^{\circ}\text{C}$  (w/heater).

If you are looking for the best in LCDs for automotive, for avionic/military or for public display applications, such as airports and financial centers (stock exchanges)... you should look to AEG where clear viewing, at any angle is superior...

For more information contact:  
AEG Corporation, Route 22 — Orr Drive  
PO Box 3800, Somerville, NJ 08876-1269  
(201) 231-8300

\*Instrument panel in first column,  
courtesy of Borg Instruments

**AEG**

NO. 6  
IN A SERIES

**Panasonic®** THE Image  
Makers

# MEASURE UP.

WITH 5" INSTRUMENT TUBES



Range from  
5 MHz to 100 MHz  
bandwidth

High deflection  
sensitivity

Available with  
or without  
internal gratitudes

Sharp focus

They may be small, but this family of tubes measures up to our strict quality standards for high reliability and long life. And their many features make them ideal for instruments or oscilloscopes.

From Panasonic...the Image Makers. For more information, contact: Panasonic Industrial Company, Computer Components Division, One Panasonic Way, Secaucus, NJ 07094. Mail Stop 4B5. (201) 348-5278.

**Panasonic**  
**Industrial Company**  
Circle no. 2

**The case for NTSC-incompatible broadcast TV**

I sat in the audience of the SID '87 evening panel entitled "Advanced Television Systems" and was dismayed to hear little discussion of anything other than enhancements to present-day NTSC broadcast television. In fact, no HDTV advocates were present on the panel (no criticism intended). But the one message that seemed to emerge, especially from the corporate side of the house, was "proceed slowly, and stick with NTSC."

During the discussion period, I made a point along the lines of "to heck with NTSC, let's get on with the future." At least a few others in the audience agreed because I was approached a number of times the next day for informal discus-

sions. Let's think about format compatibility for a moment. Does the fact that virtually every American owns an NTSC television set mean that he'll never own another kind? History certainly suggests otherwise!

Consider first radio. Initially there was AM, then FM, and they coexist today. AM radio is taking a beating due to the much enhanced sound quality of FM, but nonetheless it is the case that everyone used to have an AM radio and now almost everyone has AM and FM radios to receive totally incompatible broadcast formats. Virtually all FM stations broadcast in stereo (another incompatibility introduced along the way), and the AM radio community is struggling with adopting a stereo standard of its own.

Take a look at the audio market. In phonograph records, first we had 78 rpm

discs, and then, almost simultaneously, 45 and 33 rpm records. 33s and 45s soon became de facto standards because of improved sound quality compared to 78s, more songs per record, and less chance of breakage. In this case, 78s went away and it is virtually impossible today to buy a turntable that will play anything but 33s and 45s. In fact I often wonder why 45s still exist and even more mysteriously why they still have a big hole in the middle! And then came stereo, and people bought new equipment to hear both channels. In fact stereo records couldn't be played on older high fidelity systems without at least a new needle and cartridge. And now, we have the compact disc (CD), a new technology, even better sound, and less susceptibility to damage than 33s or 45s. Compatibility? None. Sales? In the millions in a very few years.

Now let's consider audio tape recorders. Purists will insist that first there were wire recorders, but the first in-home products were reel-to-reel recorders using 1/4-in. tape. (Remember hearing yourself on a home tape recorder the first time?) Stereo tape recorders were introduced, some compatible with mono, some not. Later, audio cassettes, which again required new recording and playback equipment, became a big hit due to their small size and comparative ease of use. And now the market is poised for the introduction of the digital audio tape (DAT) which, like the CD, should allow virtually noise-free and wear-free enjoyment of music in the home with still newer incompatible equipment.

In the video tape market, there were no home products of any consequence until VHS and Beta machines hit the market. Prior to that, an incredible number of tape formats existed in broadcast and industrial markets—2-in. helical, 1-in., 3/4-in. U-matic cassettes, etc. The "standardization" on VHS has been a long time coming—and still isn't fully settled. Now we can buy stereo VCRs, and it seems reasonable to assume that digital video tape machines will be available in a few years. *All* of these formats are incompatible from the standpoint of the home user.

*continued on page 4*

**Celco**  
**YOKES**

for  
**Best**  
**Repeatability**

**Celco**  
Mahwah, NJ 07430  
201-327-1123

Circle no. 3

# INFORMATION DISPLAY

OCTOBER 1987  
VOL. 3, NO. 9

Cover: Photograph of a white-light holographic stereogram created from terrain data provided by the Defense Mapping Agency.

The graininess of the photo is not due to film or processing, but is a characteristic of the reconstructed image.

(page 8)



Barbara Hall Photography

## Next Month in Information Display

- A large-screen fiber-optic display
- LCDs for avionics
- Matrix addressing

- 2 Letters
- 5 Editorial
- 6 Industry News
- 7 President's Message
- 8 Holographic display of three-dimensional images  
*Holography, a form of three-dimensional lenseless photography invented in 1948, has become increasingly popular for hard-copy applications. With a storage capacity equal to that of optical disks, holograms have an archival potential that has yet to be fully explored.*  
*Larry F. Hodges, Shaun Love, and David F. McAllister*
- 12 Dedicated graphics processors aid high-performance applications  
*Once banished to the computer room or laboratory, graphics processors have found a home in the modern office. Today's systems, based on VLSI technology, are incredibly fast and compact, but standardization is still a problem.*  
*Larry Morrissey*
- 15 Three-dimensional TV with cordless FLC spectacles  
*Ferroelectric liquid-crystal optical shutters make possible a simple system for home 3D viewing: cordless glasses combined with an ordinary TV set and VCR.*  
*W.J.A.M. Hartmann and H.M.J. Hikspoors*
- 18 Patents
- 22 New Products
- 31 Calendar
- 33 Chapter Notes
- 34 ID Classified
- 35 Sustaining Members
- 36 Index to Advertisers

## letters

*continued from page 2*

Lest we forget video discs, there have been two incompatible formats (capacitive and laser) of which only one, the laser, survives. Ultimately, it appears the quality of both the audio and video on a video disc may find a market, especially with the recent introduction of a player that will accept both CDs and video discs.

Now, finally, a look at television itself. In the earliest days of broadcast TV, at least three competing and incompatible formats were invented by RCA, Columbia, and DuMont. Thanks to one of those famous moments in history that John van Raalte mentioned in the June *Information Display*, a standard format, NTSC, emerged in the early 1950s as the standard broadcast TV format. In terms of in-the-

home receivers, black-and-white was the norm (many sets had VHF channels only) until the 1960s when color made a sweeping introduction and later, all TVs were required to receive both VHF and UHF channels. Since then, home TVs have become "cable ready" with the non-broadcast channels built in, and most recently reasonably high-quality stereo sound has been introduced. Is this, then, the end of broadcast TV's family tree? It certainly shouldn't be.

In all of the cases discussed above, the introduction of the newer product has been the result of some technology enhancement and hence improvement in quality from the consumer viewpoint. This improvement has in turn led to the introduction of new products which consumers have bought in almost all cases.

What more could we want from home television? Many dream of a large hang-it-on-the-wall display that would, in effect, bring a movie theater into a person's living room. Although one can buy rather large TV sets today, NTSC doesn't have high enough resolution to fully achieve the desired effect. NHK in Japan has developed and has ready to spring on the market a 1000-line HDTV system which appears to have the quantum improvement in picture quality that the consumer might like. Could this be the next in-home TV system? To transition its introduction, one can conceive of an HDTV set with a normal/high-definition switch on it, much like an AM/FM switch on a radio or a 78/45/33 rpm switch on a phonograph.

My point is: if the improved quality is there, people will buy it, and the consumer has not in the past shown that much preference for a given format. Upward compatibility is nice (e.g., FM to FM-stereo, black-and-white to color TV, etc.) but not necessary (e.g., CDs). So why build ourselves into a box called NTSC when it comes to TV systems? A new incompatible high-resolution TV format exists today (and others are no doubt in the works) which will provide to the consumer a perceived added value in home entertainment. It will probably require either direct broadcast satellite (DBS) type or cable transmission, but there's no technological breakthrough required for that. So let's get on with it. If we hadn't gotten over hurdles before, we'd still be listening to 78s and AM radio, and watching monochrome TV!

—James N. Price, SID '88 Chairman  
San Diego, California

## New LCD Modules...



## Dichroic or Twisted Nematic

IPI introduces a new line of LCD modules offering dichroic or twisted nematic designs. The custom line of LCD modules feature small size, low power and built-in electronics. They are available in alphanumeric or pictorial displays up to seven inches square with easy-user-interface and fast response time. Modules are direct sunlight readable and backlighted for total darkness legibility. Modules offer removable or interchangeable lighting schemes with high contrast, wide viewing angles and full military operating temperatures. They are available in various legend configurations including dot matrix displays. Designed and engineered

for reliability and long life, the LCDs meet or exceed requirements of MIL-E-5400, MIL-STD-704 and MIL-STD-810.

Call or write for LCD module brochure. Interface Products, Inc., 4630 North Avenue, Oceanside, CA 92056. TEL: (619) 945-0230, TWX: 910-595-2569, FAX: (619) 945-0239.



**INTERFACE  
PRODUCTS, INC.**

*What is your opinion? ID's editors welcome letters from readers on specific articles or topics of general interest to the display community. Write to the Editor, Information Display, c/o Palisades Institute for Research Services, Inc., 201 Varick St., New York, NY 10014.*

Circle no. 4

**Managing Editor:** Hildegard Hammond  
**Technical Editor:** J. Frances Tindall  
**Contributing Editors:** Ted Lucas,  
Ronald Cohen  
**Departments Editor:** Lynne A. Henderson  
**Art Director:** Hildegard Hammond  
**Advertising Manager:** Jay Morreale

## Editorial Advisory Board

Dr. Ifay F. Chang, Chairman  
*Director of Research*  
*Institute of Systems Science*  
*National University of Singapore*  
Dr. Frederic J. Kahn  
*Vice President*  
*Greyhawk Systems, Inc.*  
Koh-Ichi Miyaji  
*Professor*  
*Shibaura Institute of Technology*  
Jan Rajchman  
*Consultant*  
Aron Vecht  
*Director*  
*Phosphor Consultants*

INFORMATION DISPLAY (ISSN 0362-0972) is published monthly for the Society for Information Display by Palisades Institute for Research Services, Inc., 201 Varick Street, New York, NY 10014; David Slater, Chief Executive Officer; Leonard H. Klein, President; Harold R. Summer, Vice President; Hildegard Hammond, Secretary; Laura Mangone, Treasurer.

EDITORIAL AND BUSINESS OFFICES: Palisades Institute for Research Services, Inc., 201 Varick Street, New York, NY 10014; telephone 212/620-3371. Send manuscripts to the attention of the Editor, ID.

WEST COAST SALES OFFICE: c/o Ted Lucas, P.O. Box 852, Cedar Glen, CA 92321; telephone 714/337-6627.

SID HEADQUARTERS, for correspondence on subscriptions and membership: Society for Information Display, 8055 West Manchester Avenue, Suite 615, Playa del Rey, CA 90293; telephone 213/305-1502.

SUBSCRIPTIONS: Information Display is distributed without charge to those qualified and to SID members as a benefit of membership (annual dues \$35.00). Subscriptions to others: U.S. & Canada: \$36.00 one year, \$64.00 two years, \$90.00 three years, \$3.00 single copy; elsewhere: \$72.00 one year, \$128.00 two years, \$180.00 three years, \$6.00 single copy.

PRINTED by Sheridan Printing Company, 1425 Third Avenue, Alpha, NJ 08865. Third-class postage paid at Alpha, NJ.

POSTMASTER: Send address changes to Society for Information Display, 8055 West Manchester Avenue, Suite 615, Playa del Rey, CA 90293.

PERMISSIONS: Abstracting is permitted with credit to the source. Libraries are permitted to photocopy beyond the limits of the U.S. copyright law for private use of patrons, providing a fee of \$2.00 per article is paid to the Copyright Clearance Center, 21 Congress Street, Salem, MA 01970 (reference serial code 0362-0972/87/\$2.00 + \$0.00). Instructors are permitted to photocopy isolated articles for noncommercial classroom use without fee. This permission does not apply to any special reports or lists published in this magazine. For other copying, reprint or republication permission, write to Society for Information Display, 8055 West Manchester Avenue, Suite 615, Playa del Rey, CA 90293.

Copyright © 1987 Society for Information Display. All rights reserved.

## editorial

There are compelling reasons to consider human factors in designing a display system for the military. The tragic circumstances that led to two Exocet missiles hitting the USS *Stark* in the Persian Gulf have focused attention on the equipment in its combat information center. As an article in the Sunday, June 21, *New York Times* also pointed out, the military is increasingly relying on high-tech equipment and weaponry. Unfortunately, it is often too complex; the *Times* article cited in particular the Stinger missile. Any soldier using this shoulder-held weapon must go through 18 steps to fire it; its displays look impressive but are useless if it cannot be fired efficiently and effectively. The article lauded the M-1 Abrams tank, however. Although it is crammed with sophisticated gear, its firing system is exceedingly easy to use, being likened to playing a video game. Official blame for the *Stark* incident has been placed on three officers for lack of readiness and poor judgment, but questions about equipment reliability and problems with flawed intelligence or computer software have also been raised. The capabilities of the ship's radar and SLQ-32 electronic warfare system, one of the most highly sophisticated in the Navy, are governed by the skills of the personnel manning them. The *Stark* had a competent EW team, but apparently the audible warning system had been turned off because too many signals were being received (and anyone who has driven a car equipped with a "fuzz buster" in city traffic can perhaps understand the distractions this can cause). This action left the technicians dependent solely on visual warnings flashed on the screen. Why no threat was perceived can only be conjectured, but as with air-traffic controllers, constant vigilance is required, and no person or system is infallible.

What can be done is to develop better systems. After all, this is playing "Missile Command" for real, and reality must be taken into account in any design. Any system, no matter how far-reaching its capabilities, can be no better than the abilities of its average operator, whether a soldier, a highly trained technician, or a jet pilot. Sophisticated display systems and the ways they can facilitate operations are crucial. As Eugene Adam pointed out in his seminar at SID '87, the display industry should be seeking a greater share of defense spending. The stakes are far greater than mere financial ones.

As for this month's *ID*, we present the conclusion of our three part overview of 3D displays, this time exploring holography. Once again, Larry Hodges, Shaun Love, and David McAllister have provided a visually exciting example for the cover. In a related 3D article, Hartmann and Hikspoors describe the many possibilities that can be realized with FLC spectacles and an ordinary TV set and VCR. Larry Morrissey's story covers both conventional and 3D high-speed graphics processors.

A correction is in order to a previous editorial, in which we thanked Howard Funk for "scouring his data bases quickly and minutely." The quickness referred to his speed in supplying us with printouts, not to the hours he spends compiling his columns, gratis, and the additional time he spent on our Directory, both done minutely. He says he wants a raise. Okay, so that next month we will have to issue another clarification and thank him once again, he, like the preacher's kid in the old joke, can claim to be twice as good for nothing.

## LC shutter displays for automotive panels

Tektronix' Liquid Crystal Shutter Strategic Program Unit, Beaverton, OR, and Delco Electronics Corp., Flint, MI, have entered into a joint technology agreement. Delco Electronics, a subsidiary of GM Hughes Electronics, will have exclusive license to use Tektronix LC shutter display technology in automotive instrument panels. The LC shutter color display combines a monochrome cathode ray tube and patented LC shutter technology to produce a high-resolution field-sequential display.

## Thin-panel CRT licensing agreement

Litton Electron Devices, San Carlos, CA, and Source Technology Corporation, Los Gatos, CA, have signed a technology transfer and licensing agreement covering specific limited rights granted to Litton for a new flat thin-panel CRT technology developed by Source. Litton Electron Devices Division will offer this display in a high-brightness, ruggedized version to the military market. Source Technology will continue to develop displays and systems for the commercial and consumer markets.

## Winning graphics images at Computer Museum

Raster Technologies, Westford, MA, presents its 1987 "Computer Graphics Images" exhibit at the Computer Museum in Boston, MA. The 10 winning entries from Raster's 1986 Computer Graphics Image Contest will remain on display throughout the year. Winners of the 1986 contest include: Jane Tressel, "Two Squares at Joe's"/Grand Prize; student Colin Hui, "Porcelain Doll"/First Prize; Cranston Csuri Productions/Professional; students David Laidlaw and Barbara Meier, "Color Choreography"/Second Prize; and Marie-Andree Allaire, "Haute Aire"/Professional.

The Museum is located at 300 Congress St., Boston, MA 02210. 617/426-2800;

contact Mark Hunt, ext. 336 for details on the exhibit. Museum hours are Tuesday-Thursday and Saturday 10:00 a.m.-6:00 p.m., Friday 10:00 a.m.-9:00 p.m.

## Precision Graphic now under Sony

Precision Graphic Systems, formerly called Air Traffic Control Program Office (ATCPO), has been reorganized under the Sony Component Products Division. The San Diego-based group is responsible for developing and marketing a high-quality full-color monitor for government, industrial, and medical markets, with Sony Corp.'s engineering group in Tokyo. Teisuke Iki is the director of Precision Graphic Systems, reporting to Tatsuya Matsumoto, president of Sony Component Products Division, Torrance, CA.

## Workstation monitor agreement

Elston Electronics, Geneva, NY, has reached an agreement with Sun Microsystems, Inc., Mountainview, CA, to supply high-resolution monochrome video display monitors for Sun workstations. The multi-million-dollar agreement calls for shipments of a customized version of Elston's DM60 series monitor over the next 12 months.

## Medical equipment agreement

The 3M Co., St. Paul, MN, and Picker International, Inc., Highlands Heights, OH, have signed a multi-million-dollar purchase agreement for 3M's Imaging Systems Division to supply state-of-the-art medical imaging and film to Picker. 3M's "Laser Imager" will be supplied by Picker under its own label to the health-care industry to produce images on film for computerized tomography (CT), magnetic resonance (MR), and digital X-ray systems manufactured or marketed by Picker. The "Imager's" laser diode technology will allow extremely detailed images to be produced quickly and reliably from medical equipment such as CT and MR scanners.

## People

**Andus Corp.**, Canoga Park, CA, has appointed **Joe Gordon** senior vice president.

**Codenoll Technology Corp.**, Yonkers, NY, has appointed **Gerald M. Labie** vice president, sales.

**Dialight Corp.**, Manasquan, NJ, announces the promotion of **John McNamara** to director of sales and marketing, and the appointment of **Paul Smentek** to the newly created position of marketing manager.

**ESCO Precision Optics**, Oak Ridge, NJ, announces the promotion of **Joseph Kuchta** to head customer service manager.

**Interstate Electronics Corp.**, Anaheim, CA, has promoted **John Schwartz** to vice president, program management.

**David A. Boucher** has been elected to the board of directors of **IRIS Graphics, Inc.**, Reading, MA.

**N.A.P. Consumer Electronics Corp.**, Knoxville, TN, announces three appointments: **Thomas P. Costello**, president of sales, Philips; **Ronald E. Archer**, vice president of sales, Philco; and **John F. Williams**, national audio sales manager, Magnavox.

**Planar Systems, Inc.**, Beaverton, OR, announces the appointment of **Donald K. Klase** as account manager, sales.

**Gerald V. Butler** has been appointed vice president, engineering and scientific products, at **Prime Computer, Inc.**, Natick, MA.

**Melvin R. Goodes** has been elected to the board of directors of **Unisys Corp.**, Blue Bell, PA.

**Westinghouse Electric Corp.**, Pittsburgh, PA, announces the following personnel changes, effective January 1, 1988: **John C. Marous** will become chairman and chief executive officer; **Paul E. Lego** will become president, chief operating officer and a director. Also effective January 1, 1988, are the following retirements: **Douglas D. Danforth**, chairman and CEO; **Thomas J. Murrin**, president, Energy and Advanced Technology Group; **Douglas D. Stark**, president, Commercial Group, and **Leo W. Yochum**, senior executive vice president, finance. ■



## president's message

### Executive Committee

President: J.A. van Raalte  
Vice President: L. Tannas, Jr.  
Treasurer: W. Goede  
Secretary: P. Pleshko  
Past President: I.F. Chang

### President's Advisory Council

B. Lechner, Chairman  
T.V. Curran, W. Good, A. Kmetz, P. Pleshko,  
I. Reingold, H.G. Slottow

### Regional Directors

Minneapolis/St. Paul: R. Jamieson  
Canada: J. Wright  
Dayton: R. Holmes  
Delaware Valley: S. Filarsky  
New England: T. Cheek  
Mid-Atlantic: A. Lakatos  
Bay Area: H. Sherman  
Los Angeles: R.C. Knepper  
San Diego: R.E. Thoman  
Japan: M. Ashikawa  
U.K. & Ireland: A. Woodhead  
European: C.J. Gerritsma

### Committee Chairmen

Academic: L. Weber, L. Todd, Jr.  
Archives/Historian: R.C. Knepper  
Bylaws: A. Silzars  
Chapter Formation: A. Lakatos, C.J. Gerritsma  
Conferences  
IDRC—R. Durbeck  
Symposium—T. Credelle  
Definitions & Standards: A. Kmetz  
Honors & Awards: W. Howard  
Intersociety: H.L. Funk  
Memberships: R. Feigenblatt  
Nominations: I.F. Chang, G. Carroll, T. DuPuis  
Publications: P. Heyman  
Proceedings Editor: S. Sherr  
Information Display Editor: J. F. Tindall  
Publicity: J. Price  
Special Technologies  
Workstations—P. Pleshko  
Hard Copy—W. Lloyd

### Chapter Chairmen

Bay Area: G. Carroll  
Canada: A. Moffat  
Dayton: W. Watkins  
Delaware Valley: R. Seifert  
Japan: C. Suzuki  
Los Angeles: P. Baron  
Mid-Atlantic: R. Feigenblatt  
Minneapolis/St. Paul: V. Bohn  
New England: M. Silverstein  
San Diego: J. Lipscombe  
UK & Ireland: M. Green

### Office Administration

National Office Manager: Bettye Burdett

### Society for Information Display

8055 West Manchester Avenue, Suite 615  
Playa Del Rey, CA 90293  
213/305-1502



Every fall SID and most other technical societies send out membership renewal notices. In fact, I have already received several dues notices and all of them exceed SID's \$35 dues significantly. Nevertheless it is important that our members understand how the Society uses its dues. I have used some fiscal 1986 figures to complement available 1987 year-to-date figures in the following break-out.

Our primary sources of income in 1986 included \$48K (9.7%) from member dues, \$38.3K (7.8%) from sustaining members, \$16K (3.3%) in interest and dividend income, \$48K (9.7%) from conference operations, and \$343.2K (69%) from publications.

The income from publications includes journal (*Information Display*) advertising (76.4%), proceedings, journal, and digest subscriptions (14%), and sales of SID publications (9.6%).

Our expenses generally fall into three categories: publications (76.7%), SID office (16%), and operating expenditures (7.3%). In 1986 our expenses exceeded our income by \$53.6K largely due to very high journal operation costs; this year, with the journal management shifted to Palisades Institute for Research Services, Inc., we are of course trying very hard to close that gap.

Publication costs of \$420K included journal printing (57.6%), journal mailing costs (8.8%), journal advertising costs (13.6%), proceedings printing (19.5%), and proceedings postage (0.5%).

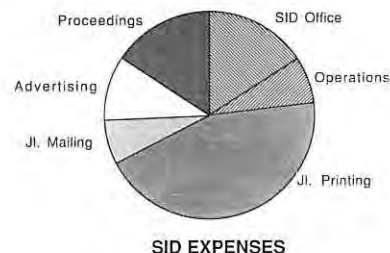
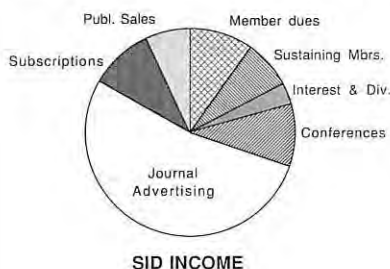

The conclusion that one can draw from this is that membership dues account for only about 10% of our income. The Society continues to function because of many other significant sources of support: our exhibitors who contribute to the profits of the Symposia, our sustaining members whose dues this year almost equal those of our regular membership, our journal advertisers, and all of the companies who allow their employees to support SID in its many volunteer activities. To you all we say "thank you"; your support makes our membership dues a bargain.

Sincerely,

# Holographic display of three-dimensional images

BY LARRY F. HODGES, SHAUN LOVE, AND DAVID F. McALLISTER

**I**N PREVIOUS articles (*ID*, May and September 1987) we have considered various methods of displaying true three-dimensional images, especially CRT-based displays and nonholographic hard copy. This month we turn our attention to the intriguing field of holographic displays.

Holography is a form of lensless photography introduced by Gabor in 1948. Although based on film recording, it does not record the image in the same way as traditional photography, and the negative it produces appears blurred or smudged. When properly illuminated, holograms can reconstruct 3D images that are virtually indistinguishable from real objects. By shifting viewing positions, the viewer can look around or over objects in the foreground to see what is behind them. Even though the hologram is recorded on black-and-white film, the reconstructed image is in color, usually monochrome, although full color is possible. Many different types of holograms can be made, with variations in both viewing conditions and fabrication techniques. Some holograms can be viewed in white light, whereas others require a monochrome light source such as a filtered mercury-vapor lamp. Perhaps the most well known is the white-light-reflection hologram. These are found on credit cards, covers of magazines and

record albums, and even as premiums in cereal boxes.

A 3D image is possible because a hologram records more information than a regular photograph (the term *hologram* means whole message). In standard photography, an image is focused onto light-sensitive film. When developed, each point on the film darkens by an amount proportional to the intensity or amplitude of the light waves that struck it. Because brighter lights cause more darkening, we have a negative image. What is not recorded by the film is the phase of these light waves.

When light from different sources is merged, the waves interfere with each other, with the resulting wave being the sum of these components. Normally, these component waves have different frequencies, and their sum varies with time. In the special case in which the frequencies are the same, a standing wave results [Fig. 1]. To record a transmission hologram, a laser beam is split into an object beam and a reference beam. The object beam is used to illuminate the subject, and part of its light is reflected to the holographic film. The reference beam shines directly onto the film. Together they produce an interference pattern containing both amplitude and phase information which the film can record [Fig. 2]. When developed, the film's darkened areas, called fringes, act as a modulated diffraction grating, and the resulting hologram is called an amplitude hologram. If the hologram is again illuminated by the reference beam from the same angle, it will diffract the light into an image of the original object [Fig. 3].

The light waves reflected from the object that would have enabled us to see it have been recorded by the film. When the image is reconstructed, the light waves viewed are the same as if those original waves from the object were passing unaltered through a transparent film.

In addition to amplitude holograms, phase holograms can be made. Rather than modulating the amplitude by blocking some of the light, all the light is allowed to pass, but its phase is modulated by varying the hologram thickness. The image is reconstructed in the same way as with an amplitude hologram but is much brighter. Phase holograms can be made by bleaching the fringes from photographic film causing a corresponding shrinkage of the emulsion. Glass substrates can be ion milled, and there is even a thermoplastic film that is reusable. Rainbow reflection holograms also work by phase modulation, and once a master has been made duplicates with the same surface relief can be stamped out by the thousands.

Because of its unique capabilities, efforts to use holography for capturing synthetic images have been continuous since the 1960s. These can be placed into two broad categories: fringe writing and multiplexing.

## Fringe writing

In fringe writing, one calculates and draws the fringe pattern required to reconstruct the desired image. Though conceptually simple and potentially quite effective, success has been limited because of the computational intractability of the

---

Larry F. Hodges and Shaun Love are visiting instructors and David F. McAllister is a professor in the Department of Computer Science at North Carolina State University, Raleigh, North Carolina.

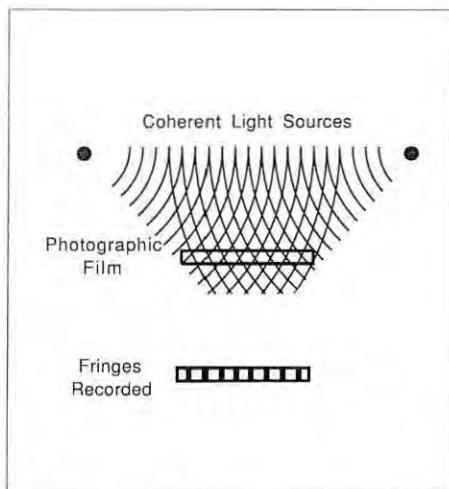

Fig. 1: Sources of equal frequency.

problem and limitations on current writing technology.

The difficulties in the calculations depend on the desired image. For planar objects the fringe pattern is given by the continuous Fourier transform, whereas for 3D objects a more complicated Fresnel transform is required. For practical considerations, discrete approximations of these are used because this allows for the use of the fast Fourier transform, and the writing device is often discrete. Vertical parallax is usually of very limited importance, and sacrificing it can realize great computational savings. In the optically generated Benton hologram, vertical parallax is removed by using a two-stage process. Between the first and second stages, a horizontal slit is used to allow multiple horizontal views but only one vertical view. Computationally, this can be achieved by dividing both the hologram and object into horizontal strips. For the top strip of the hologram, calculations can be performed by using only data from the top strip of the object. Not only does this simplify the computations, but the removal of vertical parallax also enables the image to be reconstructed using white light.

The recording or writing problem offers particular challenges. The total informational content of a hologram, called the space bandwidth product, is determined by its size and how densely the information is stored. To improve image quality, one must store as much information as possible in the hologram, but tractability is inversely proportional to this amount. Modern holographic films such as Agfa-Gevaert 8E75HD have a resolution of

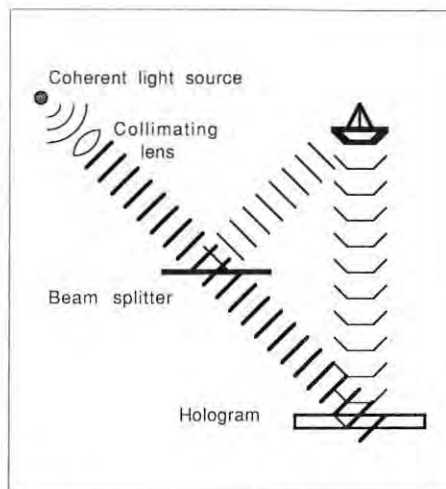

Fig. 2: Recording a transmission hologram.

5000 lines/mm and a grain size of 30 nm (as compared to 185 lines/mm for Agfapan-25 professional, a film commonly used in photography). Although this extremely high resolution makes high-quality optically recorded holograms possible, it is beyond the capacity of current computer output devices to exploit it.

Efforts to approach this resolution began by using plotters to make large-scale drawings that could then be photoreduced. Surprisingly, for very simple objects such as planar stick figures, extreme demagnification is not needed to obtain a discernible but noisy image. Photoreduction has largely been replaced by methods of writing the pattern directly onto a substrate. Electron-beam writers can obtain submicron resolution but record a binary pattern. The substrate used is chrome on glass, and any point is either transparent or opaque. A gray scale can be introduced by halftoning, but only at a loss of resolution. Aerodyne Research has developed a system that can produce continuous tones on holographic film. Their holowriter uses a very high-resolution CRT with  $2000 \times 800$  pixels. This is divided into cells, and halftoning is used to produce a gray scale in each. An image of this CRT is demagnified and used to expose the film. Various problems with the film exposure and the halftoning method limit the resolution to approximately  $5 \mu\text{m}$ .

The low resolution of current plotting devices results in several problems. The low space bandwidth product causing image degradation has already been mentioned. In addition, problems occur in trying to view a reconstructed image.

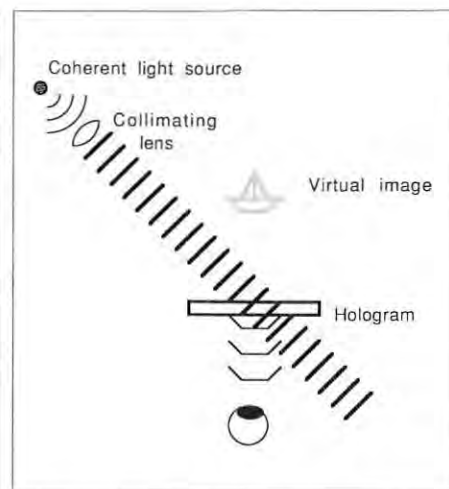

Fig. 3: Replaying a transmission hologram.

Widely spaced fringes produce only a small separation of diffraction orders, so that the reconstructed image (first diffraction order) is only slightly removed from the bright light that passes directly through the hologram (zeroth order). This can make viewing difficult, and large images from adjacent orders may even overlap. In addition, there is usually a low diffraction efficiency which results in a dim image, although brightness can be improved by making a phase hologram. At present, fringe-writing capabilities are still very poor.

The primary difficulty with fringe writing is the inability of output devices to draw the pattern at the requisite resolution. To overcome this limitation, multiplex holograms revert to the proven technique of recording the hologram by laser. A series of computer-generated perspective images is produced, and by multiple exposures all are recorded onto the same hologram. Two different methods can be used, depending on the type of data and image required.

*Holographic stereograms* use a hologram for recording multiple stereo pairs. If a hologram is covered by a sheet of cardboard with a peephole cut in it, then by looking through the hole the entire object can still be seen. If the peephole is small enough, only one perspective view is available. To produce a holographic stereogram, the hologram is subdivided into many such peepholes. For each of these, the perspective view it affords is calculated, rendered on a CRT, and photographed. Finally, a laser is used to record a holographic image of the photo into the peephole or subhologram.

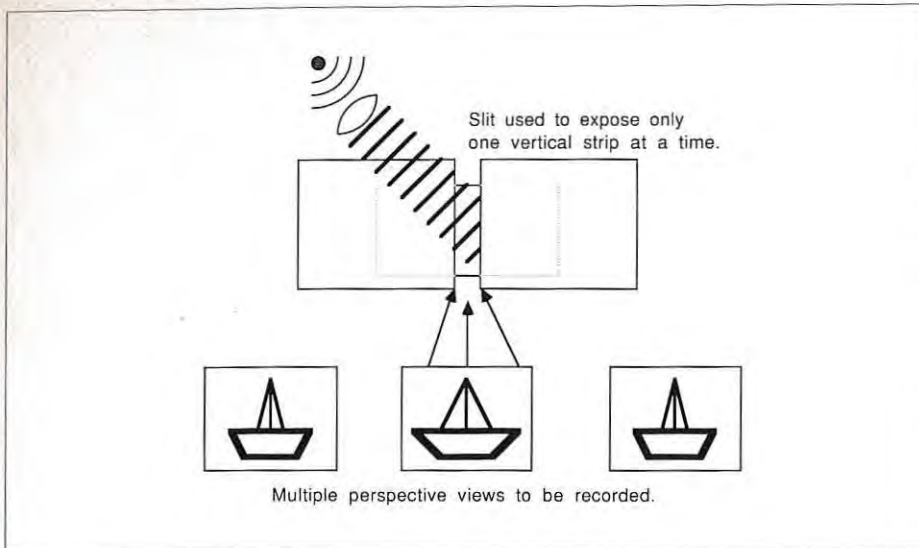

Fig. 4: Recording a holographic stereogram.

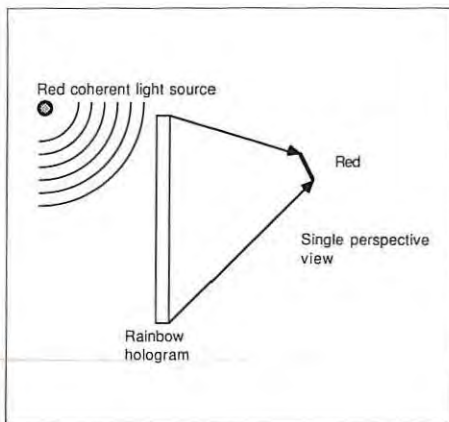

Fig. 5a: Rainbow hologram, monochromatic source.

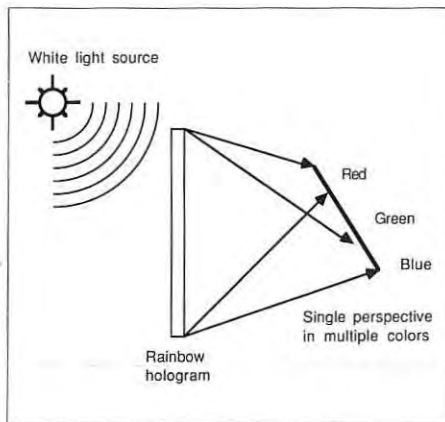

Fig. 5b: Rainbow hologram, white-light source.

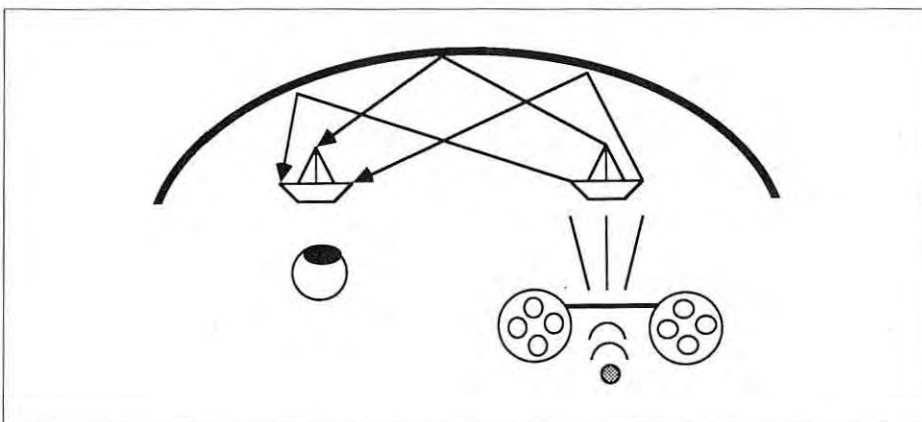

Fig. 6: Holographic cinema.

When the finished hologram is illuminated, each eye looks through a different peephole, and thus the viewer is presented with a stereo pair. Disconnec-

tion of accommodation and convergence exists, as with any stereo-pair technology.

Because only a finite number of stereo pairs can be recorded, it is necessary for

the extent of each subhologram to be no greater than the diameter of the pupil, so that as the eyes move the perspective changes smoothly rather than in discrete jumps. For most people, 3 mm is adequate. Once again, it is useful to simplify calculations by eliminating vertical parallax. Rather than 3-mm-square peepholes, the hologram is usually divided into narrow vertical strips, with each recording the view from only one height [Fig. 4]. This has the added advantage that it can be viewed in white light. A popular form of this is the Cross hologram or white-light cylindrical holographic stereogram. Here a virtual image is seen floating within a cylinder. If the stereogram is made from photos of a real object, then distortions occur when viewing at an angle, but for computer-generated images, the view can be predistorted in the opposite direction to compensate for this. An interesting and useful variation is to record the object while it is in motion so that each view is from a slightly different perspective in both space and time. Moving the head from side to side allows not only a look-around in space but also forward and backward motion. This could be used to advantage in demonstrating a sequence of steps such as in a complicated assembly process. A problem with this is that there is a temporal distortion, because what is seen by each eye is from a different point in time. Thus, one eye could see two objects coming together while to the other eye they have already met.

At MIT work is currently being carried out by Stephen Benton on what is called an Alcove hologram. This hologram is illuminated from the rear while resting in a semicircular frame, from which it gets its name. Acting like an inside-out cylindrical hologram, it produces a real image that seems to float in front of the hologram, with the alcove serving to frame it. The hologram is composed of approximately 1000 separate perspective views recorded into adjacent strips. It currently takes several days to produce, but it is expected that this time will be shortened to a single day.

A different type of multiplexing is needed when the data are multiplanar, that is, when providing serial slices through an object such as in the case with CT scans and other medical-imaging techniques. Here a 3D view is gained by stacking the images one on top of another. It is little trouble to record multiple exposures on a single sheet of

film that can reconstruct independent images. Consecutive slices are recorded at appropriate distances, and the reconstructed image is of a semitransparent solid object. There is a limit to the ability of the film to record superimposed holograms, but stacks of at least 12 have been demonstrated.

### Adding color

As in standard photography, full color is achieved through the combination of three images, each in a different primary color. Rainbow holograms are a variation of monochrome, because different colored versions of the same image can be viewed but there is no color mixing. They can be reconstructed in white light because of their lack of vertical parallax. Recall that to make a rainbow transmission hologram, a horizontal slit is used. If a monochromatic light source is used to reconstruct an image, then what is seen is an image of that slit [Fig. 5a]. Should a two-color source be used, then the hologram separates the colors by diffracting them through different angles, and two separate monochrome images of the slit can be seen. With a white-light source, a continuous range of colored slits is smeared in the vertical direction, giving the familiar rainbow appearance [Fig. 5b].

It is possible to produce a full-color holographic stereogram by superpositioning three rainbow holograms in each vertical strip. For this, a color image is separated into its RGB components. By using different angles of the reference beam, they are recorded so that the one desired color from each reconstructs together at the same vertical position. When viewed at the proper height, the RGB images blend to give the desired coloration. Head movement is restricted to this one level, because incorrect coloration is seen at any other.

Correct registration of the RGB images is a critical task and is more difficult than it may first seem. A problem with rainbow holograms is that only the color that is the same as that used to construct the hologram can reconstruct a faithful image. All other colors are diffracted through different angles horizontally as well as vertically and produce images that differ in size, proportion, and distance from the hologram plane. For the RGB images to blend properly, each must be recorded by a laser of that color. Otherwise, the images would be different sizes and separated into different planes. If multiple lasers and a recording medium

sensitive to a wide spectral range are not available, then some distortion occurs.

### Holographic cinema

The ability to present autostereoscopic 3D movies has excited the imagination long before moviegoers watched R2D2 deliver his holographic message. Although this was accomplished in Hollywood by special effects, a 45-sec holographic motion picture was successfully demonstrated in the Soviet Union over 10 years ago—before Star Wars. In the system developed at the Russian Cine and Photo Research Institute, the screen is an elliptical mirror. A viewer sits with his or her head positioned near one of the focal points while a series of real holographic images is projected to the other [Fig. 6]. Because of the geometry of the mirror, light from the image that strikes any point on the mirror at any angle is reflected back toward the viewer. To accommodate more than one viewer, the screen is actually a holographic optical element that functions as several superimposed elliptical mirrors. Fabrication of such a screen for group presentations is difficult, and the Soviet screen restricts the number of viewers to a maximum of four at a time.

### Archiving

Holograms can be used to make permanent copies of vast amounts of information in a very small space. For example, in a holographic ultrafiche file system, over 12,000 pages of information can be stored by a 4 × 6 in. hologram. This density is similar to that obtained by optical disks, but here the information need not be text. This vast storage capacity can provide a redundancy of information that makes a hologram remarkably damage resistant. If all but a fragment of an optically generated hologram is destroyed, an image can still be reconstructed. In fringe writing, efforts are made to minimize this redundancy so as to simplify computations and better utilize the limited space bandwidth product. With multiplex holograms, the redundancy is preserved at least in part. If the top half of a holographic stereogram is covered or destroyed, all the horizontal views are still available, though with less sharpness.

Problems of long-term archival storage vary, depending on the medium used to fabricate the hologram. Photographic emulsions are subject to distortions caused by changes in temperature and humidity. Some holograms can even

undergo a noticeable color change when exposed to warm breath, so that control of temperature and humidity is needed. Glass plates are easier to work with than film for both recording and replaying the image, but they are heavier than film, require more space for storage, and are subject to breakage.

### Summary

Holograms are capable of presenting viewers with extremely realistic images by recreating the same optical wavefront reflected from the original object. As a result, a true 3D image can be seen with all the associated depth information available to the viewer. Holograms generated by computer are produced by either fringe writing or by multiplexing multiple CRT images. Fringe-writing capabilities are still very poor, with this low quality due to current technological limitations. Multiplex holography circumvents this limitation by using optical means to record many different perspective views. High-quality multiplex holograms have been created, and the added feature of apparent motion can be achieved by holographic stereograms. A drawback of holographic stereograms is that only flat projections of an object are recorded, so that depth cues such as accommodation are not available to the viewer.

Because of their extremely high informational content, computer-generated holograms require large amounts of computation, and production time is significant. Holograms are well suited for archival purposes, although some care should be taken to protect them from adverse environmental conditions. Otherwise, they can be quite resistant to damage. For hardcopy applications in which realism is a primary concern, holography will find an increasingly important role in computer information display.

---

### Acknowledgements

The cover photo is of a white-light holographic stereogram generated from terrain data provided by RADC and the Defense Mapping Agency. The images were produced at North Carolina State University and the stereogram was recorded by Dr. Maurice Halioua of the New York Institute of Technology. Special thanks to Barbara Hall of Barbara Hall Photography. ■

# Dedicated graphics processors aid high-performance applications

BY LARRY MORRISSEY

**T**ODAY, the term computer graphics has almost as wide a meaning as the term computer. The computer graphics industry covers a wide range of applications and products, from microcomputer-based business graphics through more sophisticated CAD/CAE workstations to high-performance dedicated graphics systems for such sophisticated applications as solids modeling or real-time mapping.

The market for computer graphics can be divided into three major segments. At the low end, microcomputers like the IBM PC and Apple Macintosh can support business graphics and entry-level CAD/CAE applications. In the mid-range, engineering workstations such as the Sun 3/260 and Apollo DN 3000 provide much better graphic performance and feature greater speed, higher screen resolution, and more powerful software. These systems, which are aimed at engineering and scientific applications, also provide a rich computing and networking environment ideal for specialized applications. At the high end, dedicated graphics processors such as the Chromatics Le Mans [Fig. 1] and Megatek 9100 work as a peripheral tied to a powerful host computer such as a VAX to provide the highest possible graphics performance.

An accepted method for segmenting the market for computer graphics is based on vector speed, the mathematical expression

that represents a series of pixels or dots on a display screen. A system's ability to draw a vector on the screen—including a full transformation (which means rotating, moving, and sizing the vector)—is an accepted measurement of graphic performance. Low-end systems can generally draw fewer than 70,000 fully transformed 10-pixel two-dimensional (2D) vectors/sec. Mid-range systems range from 70,000 to 200,000, and high-end systems exceed 200,000 vectors/sec.

Although the market for business graphics and mid-range CAD/CAE computer graphics is larger than the high-performance graphics market, the high-speed market is important for two reasons. First, some applications must have the highest possible speed and resolution. Second, today's high-speed technology often becomes tomorrow's mainstream products. In fact, the advances made in 2D systems by companies like Chromatics and in 3D systems by companies like Evans & Sutherland will likely find their way into other systems as very-large-scale integrated circuit (VLSI) technology brings down unit costs.

## How high-speed works

Figure 2 shows a typical configuration diagram of a high-performance graphics system. The key element is the graphics engine or processor. In most systems the graphics engine is actually a sophisticated computer that consists of a series of processors, memories, and special-function modules. The role of the graphics engine is to process all graphics information and manage the display screen, offloading the host from this task. By way of com-

parison, this function is often performed by a graphics chip or video card in less powerful systems.

The two most important features of high-performance systems are speed and resolution. Speed is important in applications in which screens must be drawn and redrawn quickly, such as in real-time simulation, solids modeling, and high-performance mapping systems. These types of systems also require high-resolution displays because they deal with precise information and make full use of color. The standard 1280 × 1024 display found on most high-performance systems is ideal for these applications, although there are even sharper displays that offer 1536 × 1152 resolution.

A closer look at the design of Le Mans, which was introduced in June by Chromatics and is the first graphics system to break the 1 million 2D vectors/sec barrier, shows the sophistication and complexity of today's high-performance graphics systems. Le Mans' graphics engine [Fig. 3] is built around an industry-standard VME bus, which is the main physical interconnect for the system and provides an open architecture for users to add enhancements or options. Up to 21 VME modules can be configured. The major elements of the system communicate over a set of high-speed 32-bit-wide private buses, a key element of Le Mans' pipelined architecture. While one element of the system is processing data, another element can be processing, sending, or receiving other information. The private buses eliminate the contention present in single-bus systems, reducing wasted time and speeding up throughput.

---

Larry Morrissey is the technical marketing manager of Chromatics, Inc., Atlanta, Georgia.

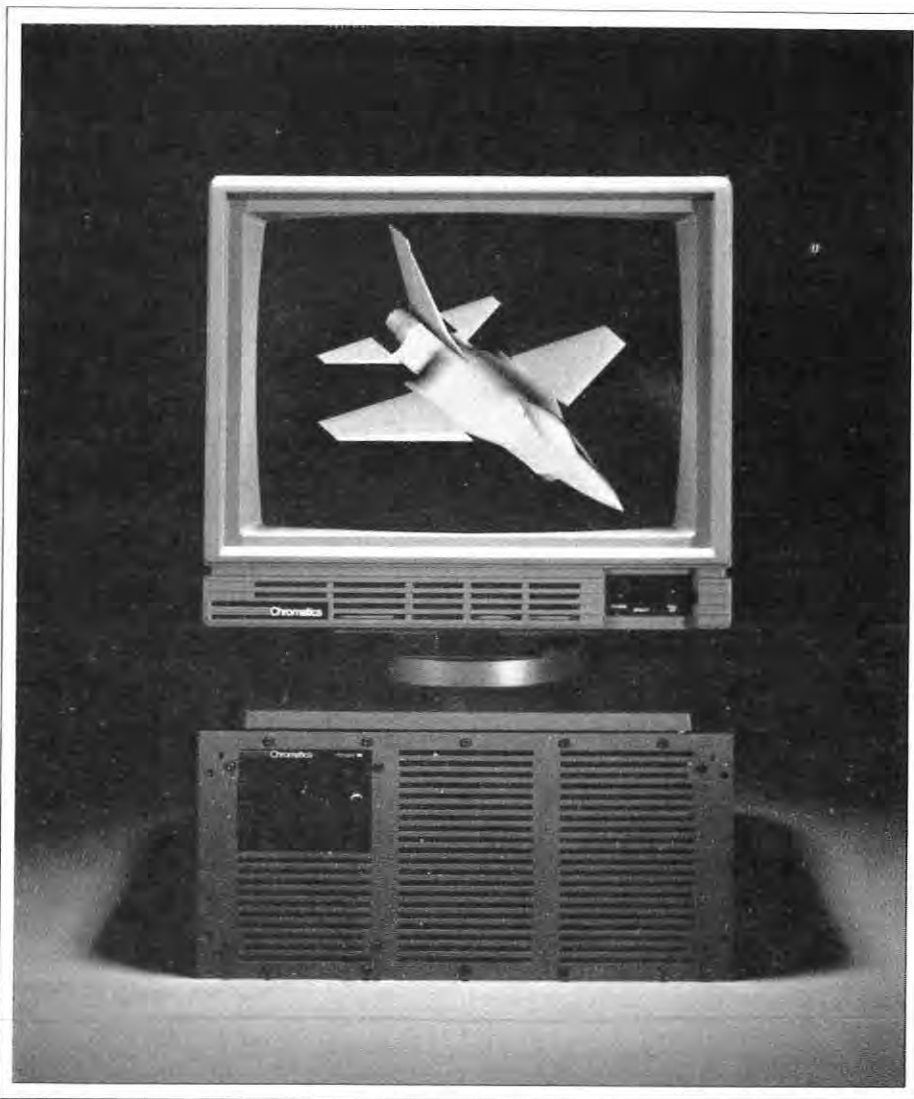

*Fig. 1: Le Mans Colorgraphic display system by Chromatics, Inc., achieves 2D drawings speeds in excess of 1 million vectors/sec. A 3D image of the F-16 aircraft is displayed.*

### High-speed applications

Typically, an application program running in a host such as a VAX or a Sun system sends graphic data in the form of vectors or polygons to the graphics engine. The most common way for the raw data to enter the graphics engine is through a high-speed parallel port via a DR11-W type direct memory access (DMA) interface. Optionally, the system supports either Ethernet or high-speed serial data transfers. The data are initially stored in the dual-ported display-list memory, which has a 240-nsec cycle time and a capacity of up to 32 Mbyte. From there, the data travels through a high-speed private bus into the display list processor (DLP). The DLP consists of a 32-bit CMOS processor running at 12

million instructions/sec closely coupled with a floating-point array processor running at 20 million floating-point instructions/sec. All Le Mans calculations are done in standard IEEE 32-bit floating-point format. The DLP's function is to take the raw vector data and transform it. This includes rotating, translating (moving), and scaling (sizing) the data. In addition, the DLP calculates polygon edges and clips or eliminates the edges of the image that fall outside the display window.

In 3D applications the processed vector information flows into an optional shading processor, which adds flat or smooth shading. Smooth shading is accomplished by the Gourard algorithm using hidden surface removal, which automatically deletes those image surfaces

that should not be displayed—for example, the wing of an airplane that is turned away from the viewer. A 16-bit depth buffer stores the hidden surface data, which can be accessed again when needed.

The information then flows into the high-speed hardware vector generator which converts the processed vector data into pixel data for display on the screen. The pixel data is then placed into bit-mapped memory which corresponds to the pixels on the display screen. The bit-mapped memory has four planes of double-buffered memory consisting of  $1280 \times 1024$  arrays. Double buffering allows one set of memories to be updated or written while the other is being displayed. Swapping buffers enable the system to display the newly created image while preparing the old image for update or replacement.

Finally, the color lookup sync converts the pixel data values from the bit-mapped memory into analog voltages that represent the color values to be displayed on the screen. In addition to color conversion, the color lookup sync generates all video timing used to fetch, format, shift, and blank the video screen.

In addition to a highly optimized hardware architecture, another important feature of Le Mans is its microcoded version of either GKS (graphical kernel system) or CX3D software. GKS is a standard graphics language for 2D display systems. By having the GKS primitives microcoded, each instruction executes in hardware, thus considerably speeding up processing time and contributing to the 1 million vector/sec performance. Similarly, CX3D, a PHIGS-like (programmable hierarchical interactive graphics standard) software program, provides the same high-speed processing in 3D applications.

Two systems that display graphical information in near real-time and thus require a dedicated graphics processor to offload the host are Softscreen from Softech, Inc., Fairborn, Ohio, and TRACE from Lockheed Missiles & Space Co., Austin, Texas.

Softscreen is a unique display prototyping system that consists of two modules. The first provides for rapid development of display prototypes such as instrument panels, cockpit displays, and process control panels. The second module is an emulation editor designed to simulate the operator/system interfaces of the prototyped displays.

The prototyping system provides an easy-to-use set of tools which allow the

designer to combine graphic primitives such as lines, circles, and arcs to create original symbols. In addition, pre-constructed libraries of standard symbols are also available. These symbols include military aircraft (MIL-STD-1787), flowchart, circuit, and World Meteorological Organization (WMO) symbols. The original and predefined symbols are combined to design display panels.

The second module (the emulation editor) manipulates the displays by allowing transition between displays. The designer selects symbols (e.g., buttons, knobs, and keypads) on one display and links these to another display. In this manner, a display transition tree which controls the emulation is built. Once the tree is defined, the end user or operator can exercise the tree, simulating the actual operation of the system.

The Softscreen prototyping system runs on the VAX series of computers using the Chromatics CX 1280 display system, a software-compatible predecessor of Le Mans that can draw 500,000 2D vectors/sec. TRACE also runs on the VAX and CX 1280. TRACE is targeted toward military command, control, communication, and intelligence (C3I) applications. It combines high-speed computer graphics with operations research and mathematical algorithms to produce a near-real-time assignment of tactical resources. Utilizing a simple menu-oriented command language, the operator builds high-resolution background maps and then symbolically positions land, air, and naval forces and installations on the maps to project the current tactical situation. Sophisticated algorithms then calculate optimum resource deployment using target and weapons status information, weapons effects, receiver and jammer information, limiting factors, and command guidance information.

### Looking ahead

In the future, dedicated graphics systems will become faster, smaller, and more standardized. Speed will be needed to process increasingly sophisticated real-time applications, smaller sizes to facilitate wide-scale adoption, and standardization to make high-speed graphics more cost effective and to reduce customer reliance on a single vendor.

Today 1 million 2D vectors is a reality. Evans & Sutherland's model PS390 can draw 365,000 3D vectors/sec. In the near future, current barriers will fall as vector speeds double.

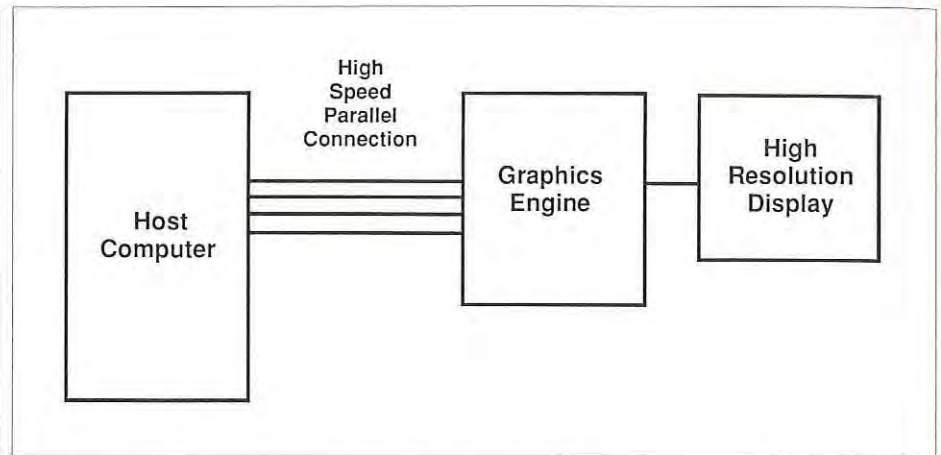

Fig. 2: Typical configuration of a high-performance graphics system.

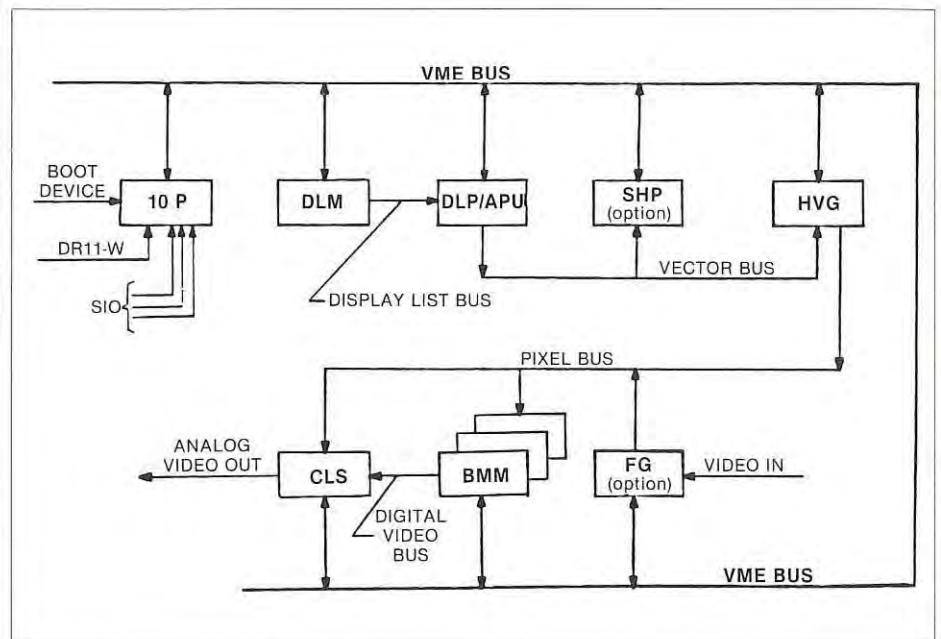

Fig. 3: Block diagram of the graphics engine of Le Mans Colorgraphic by Chromatics, Inc.

Just a few years ago dedicated graphics systems were large cumbersome machines relegated to the computer room or the laboratory. Today, through the use of VLSI technology and advances in display technology, these same systems can sit in an office, either on a desk or in floor-mount/tower configuration. Tomorrow's systems will be even smaller, with high-performance graphics in excess of 1 million vectors packaged in a fully functional desktop workstation.

Standardization is a universal problem in the computer industry. With software it is an important trend. GKS is virtually a de facto standard for 2D graphics processing. GKS bindings are now available

under UNIX, VMS, MS-DOS, and other major operating systems, so that application programs written in Fortran, C, Pascal, and other popular languages can access GKS. Standardization also helps increase application portability.

On the hardware side, however, there has been very little standardization among graphics system vendors. Le Mans was designed around the industry-standard VME bus to give customers more options and encourage an add-in market in graphics processing. It seems likely that because graphics processors are really specialized computers, they will converge around as many existing computing standards as possible. ■



# Three-dimensional TV with cordless FLC spectacles

BY W. J. A. M. HARTMANN AND H. M. J. HIKSPOORS

**T**HE EFFORT to realize three-dimensional television with a simple configuration never ceases. Most of the realistic suggestions are based on presenting separately to the left and right eye two different images, recorded by two cameras viewing the scene from two different angles. The observers' brains are tricked into interpreting this information as a 3D sensation. Spectacles always seem necessary; passive spectacles divide the simultaneously presented information into the two different viewing angle images. For instance, when each view is given a color, in which case the glasses consist of two different color filters, a monochromatic 3D image is obtained. When two monitors with differently polarized light and a semitransparent mirror are used, the glasses consist of two differently oriented polarizers, making full-color 3D possible.

Ferroelectric liquid-crystal (FLC) optical shutters have reached the point at which they can be applied in commercial products such as ultrafast black-and-white light valves featuring low power, high contrast and brightness, and a wide viewing angle. In field-sequential stereoscopy, an ordinary television set and VCR need only to be extended with a trigger-transmitter and a pair of glasses, consisting of two FLC shutters, a trigger-receiver, and a low-power supply, to ob-

tain clear 3D images.

With field-sequential stereoscopy, the images are not provided simultaneously, but one at a time. A home color TV set working at 50 or 60 Hz presents its image by interlacing two half-images (the even and odd lines) at 25 or 30 Hz, resulting in a flicker-free image. The left and right views recorded by the camera and VCR must be added to each other on one video tape or disk in such a way that one half-image (for instance, the odd lines) consists

of the left view, while the other half-image (even lines) displays only the right view. This information is displayed on one monitor. The observer should be supplied with active spectacles, which open and close at the same frequency and in the same phase as the monitor's half-images. In this way the observer's left eye sees only the half-image of odd lines and the right eye sees only the half-image of even lines, resulting in two-image 3D [Fig. 1].

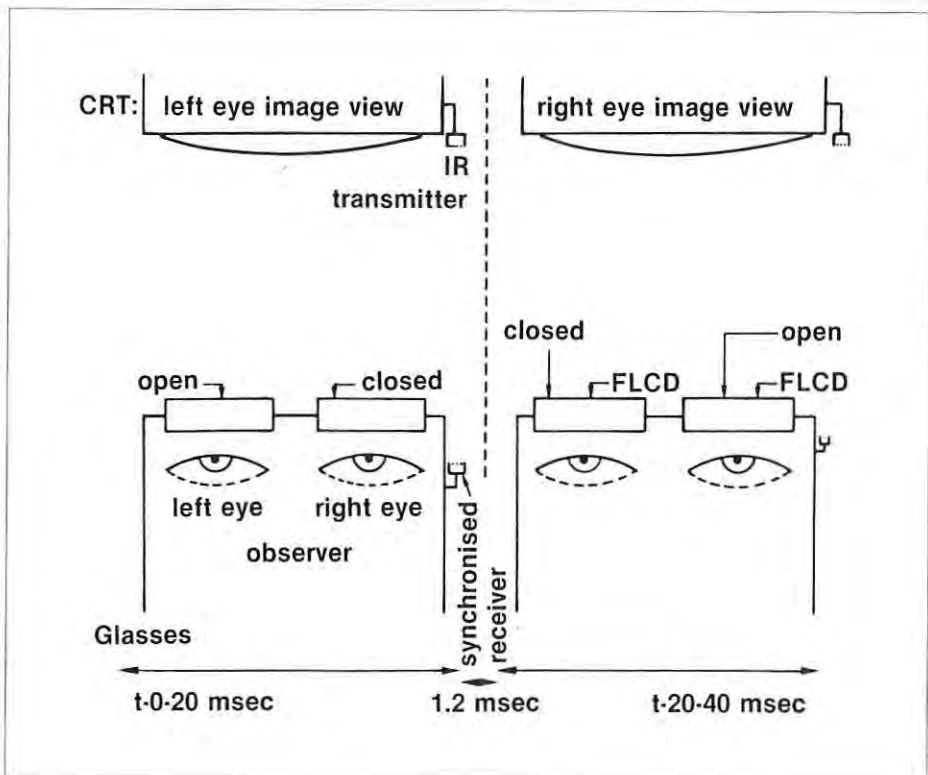

W. J. A. M. Hartmann is a researcher at Philips Research Laboratories and H. M. J. Hiksdoors is a development engineer at Philips Consumer Electronics, Eindhoven, The Netherlands.

Fig. 1: Field-sequential stereoscopy.

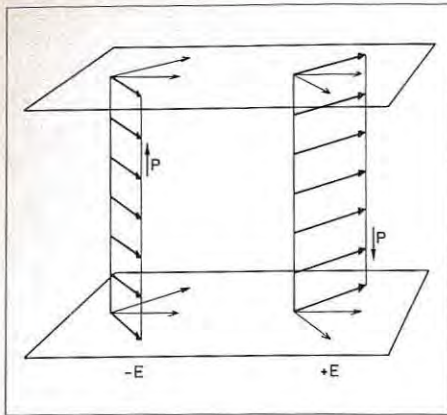

Fig. 2: SSFLC structure.

The most important condition for the spectacles is the short open and close time. After writing one half-image (about 270 lines), the electron beam needs less than 1 msec to return to the top of the cathode-ray tube and start displaying the other half-image. This means that if the optical shutter does not fully close or open in this 1 msec, the 3D sensation will be lost in the top part (first lines) of the image. Other conditions are high contrast and colorless brightness to obtain as much visual information as possible and low-power driving so that the spectacles can be portable or even cordless.

### Problems with past systems

In the past, several light-valve devices have been suggested for use as glasses. The only candidate with the desired switching speed was the ceramic PLZT shutter. Unfortunately, PLZT not only has a very low transmission, but it also needs switching voltages of around 600 V, which is likely to melt the wiring and electrodes. Attention soon shifted toward liquid-crystal effects, where the main drawback has been the switching time. The twisted nematic (TN) LCD needs at least 20 msec. Dynamic scattering effects can reach 5 msec, and two-frequency mixtures go down to 2 msec at the limit.

Years of optimizing have recently resulted in two improvements. Milgram and van der Horst<sup>1</sup> published results obtained with phase-changing cholesteric nematic scattering liquid-crystal cells. These cells need 80- to 100-V switching pulses and 50- to 60-V maintaining voltage to reach a switch-on time of approximately 1 msec and a somewhat longer turnoff time, which can be electronically manipulated to be satisfactory.

The cells switch between 100% transparent (without polarizers) and a

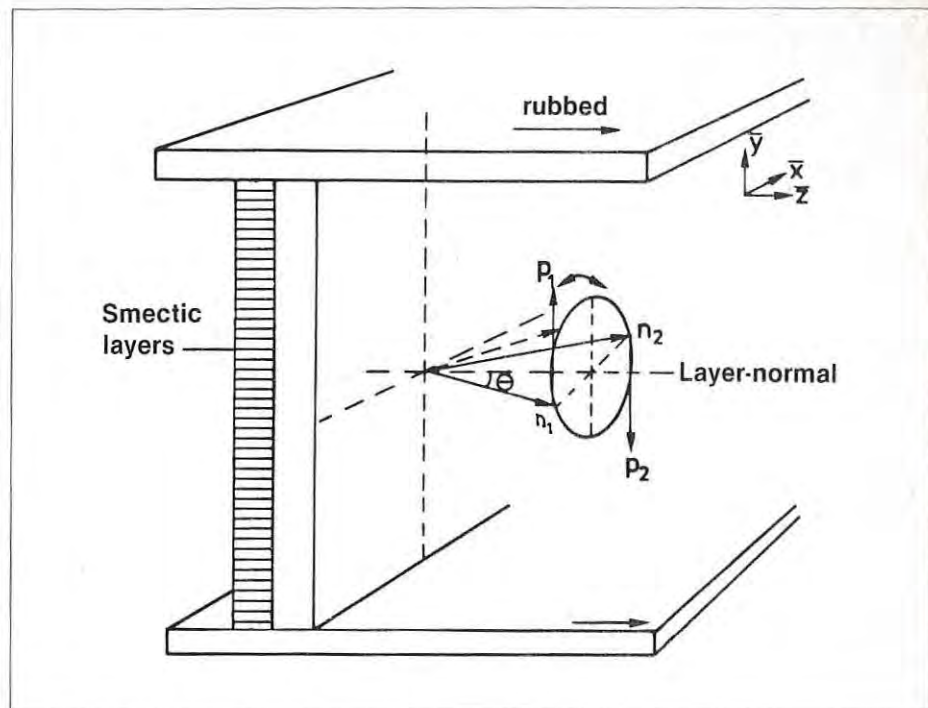

Fig. 3: SSFLC switching.

scattering white state, which may have a degrading effect on the 3D quality because half of the total amount of light then reaching the eye contains no information at all. Even more recently Iwasaki<sup>2</sup> has reported the development of a 3D medical X-ray TV system, which operates an improved TN-type liquid-crystal cell with a rise time of less than 1 msec. It is driven with a "comparatively safe" 30 V.

### The SSFLC solution

The surface-stabilized ferroelectric liquid-crystal effect (SSFLC) structure is a new liquid-crystal effect that is very suitable for this application. In 1980 Clark and Lagerwall<sup>3</sup> invented the SSFLC structure, based on the possibility of using the ferroelectricity of liquid-crystal molecules in the chiral tilted smectic-C phase efficiently. It was not until 1985, however, when chemical companies succeeded in lowering the temperature area in which the smectic-C phase exists from about 100°C to about 20°C, that commercial application was seriously considered. The SSFLC structure [Figs. 2 and 3] is based on a homogeneous aligning of the LC molecules at the surfaces of the glass plates to make sure that the permanent electric dipole on the molecules will always be parallel or anti-parallel to the electric field.

By decreasing the distance between the glass plates, the homogeneous surface orientation is also kept in the bulk of the LC layer. In this way each molecule has only two possible directions; switching the polarity of the electric field causes them all to be in one state or in the other at the opposite polarity. This behavior is bistable. With the aid of two crossed polarizers, it is thus possible to switch between black and a birefringent color, depending on  $D\Delta n$  (cell thickness and optical anisotropy) according to the formula:

$$I_{on} \sim \sin^2(4\theta_T) \sin^2(\pi D\Delta n / \lambda).$$

$$\theta_T = \text{smectic tilt}$$

As can be seen, the optimum smectic tilt angle is 22.5° ( $4\theta_T = 90$ ), and the preferable  $D\Delta n$  should be about 0.28  $\mu\text{m}$  to obtain zero-order birefringent transparency with the highest brightness. Calculated color coordinates are depicted in Fig. 4 as a function of  $D\Delta n$ . It is seen that perfect white is nearly attainable.

Technological problems in realizing SSFLC cells are alignment and spacing, which is 2.0  $\mu\text{m}$  (three times less than that of the common TN cells). SSFLC cells have been made using nylon as an orienting layer, the hot-fill and press method to construct the cells, and a Merck room-temperature smectic-C mixture (ZLI 3234). These cells show black versus

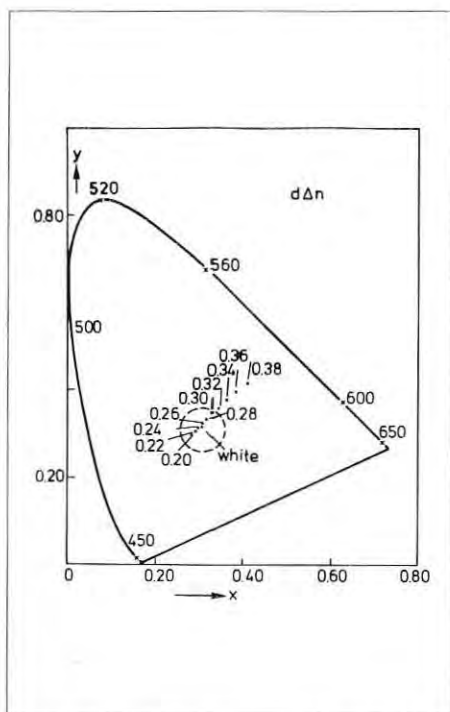

Fig. 4: Color coordinates for birefringent states.

colorless-transparent switching, scarcely any viewing angle dependence, high brightness and contrast (1:50), fast low-power switching, and reasonable temperature stability. With a 3-V square wave the switching time is about 400  $\mu\text{sec}$ . This means that these cells are very suitable for 3D TV spectacles.

#### How the system works

A VCR supplies the monitor with field-sequential stereoscopic images. The monitor is provided with a detachable infrared transmitter for the 50- or 60-Hz synchronizing signal. The viewer wears FLC spectacles that incorporate an infrared receiver to pick up the synchronization. Power is supplied by two built-in small mercury batteries, and the SSFLC glasses open and close in phase with the TV set's half-images. Because the power needed is so low (3 V and  $I < 0.1 \text{ mA}$ ), it is no problem to fit the receiver and the power supply in the setting of the glasses [Fig. 5].

The result is an impressive 3D picture, especially with TV sets operated at 60 Hz. European TV sets are operated at 50 Hz. This means that the stereoscopic image shows a 25-Hz flicker, which is noticeable and varies with image brightness. Sets in the United States and Japan operate at 60 Hz, causing the flicker to be 30 Hz, which is much less noticeable because this is the critical flicker-frequency area. To avoid



Fig. 5: Cordless FLC spectacles and IR transmitter.

flicker completely, it is possible to double the frame frequency of the TV set and VCR, in which case the flicker frequency will not be detectable by the human eye. The time between the two half-images will be shorter, but the switching time of the FLC shutters is clearly fast enough, even for 100 Hz. Of course, this 100-Hz setup cannot yet be implemented with home TV sets. However, marketing of 100-Hz sets for other purposes can be expected in the future.

With a 50-Hz TV, we have made a comparison with the first commercially available (October 1986) Japanese 3D spectacles, which are based on nematic LC shutters. These are operated at  $\pm 12\text{-V}$  square wave and are not cordless. Closing time is less than 1 msec, but opening the LC shutter requires from 2 to 6 msec (50-90%) transmission. The insufficient opening speed causes a loss in image intensity (brightness) that is quite noticeable. The same scene observed through FLC spectacles results in a much brighter 3D picture.

The advances of FLC field-sequential stereoscopy are:

- It is compatible with both home TV systems and broadcast systems.
- The only accessories needed are spectacles and transmitter.
- Full-color 3D is possible.
- The spectacles consume low power (3 V,  $I < 0.1 \text{ mA}$ ).

- It is easily portable, and cordless spectacles allow free movement.
- There is no limit to the number of simultaneous users.
- The switching speed is even fast enough for absolutely flicker-free stereoscopy at 100 Hz.

Field-sequential stereoscopy combined with FLC spectacles, giving optimal performance, high speed, and low power consumption, can provide the most user-friendly (cordless) system of 3D television viewing. Home TV set compatibility assures many applications.

Future applications are virtually unlimited. Some possibilities are: 3D medical systems, (X-ray, NMR tomography, echoscopy); 3D scientific instruments (i.e., for electron microscopy); 3D computer-aided design, manufacturing, and graphics; 3D flight and traffic simulation; 3D consumer electronics specialties and games; and 3D consumer programs, either off-the-air or from tape or disk.

#### References

- <sup>1</sup>Milgram and Van der Horst, *Displays*, Vol. 7, No. 2 (1986), p. 67.
- <sup>2</sup>Iwasaki and Hori, *Japan Display '86: Proceedings of the Sixth International Display Research Conference* (1986), p. 578.
- <sup>3</sup>Clark and Lagerwall, *Appl. Phys. Lett.* Vol. 36, No. 11 (1980), p. 899. ■

Compiled by HOWARD L. FUNK  
IBM CORP.

*U.S. Pat. No. 4,670,690; Issued 6/2/87*  
**Thin-Film Electroluminescent Display Panel**

*Inventor: RICHARD D. KETCHPEL*

An electroluminescent (EL) material sandwiched between parallel strips of electrodes running at right angles to each other is described. Pixels are formed where the electrodes cross to provide a thin-film EL display. The display includes a layer of insulating material which has a hole at each pixel. The backside electrodes extend into the holes, thus providing a high electric field only at the pixel locations. These backside electrodes are broad to assure electrical continuity despite any open circuit created by burned-out pixels. The insulating material overlaps the edges of the frontside electrodes, thus reducing the electric field which concentrates at the electrode edge. The insulating layer and the backside electrode can be made black, or a light-absorbing semi-insulating layer used in order to reduce light scattering and reflection. Transparent electrodes can be used to allow light to emit from either the front, the back, or both sides of the display.

*U.S. Pat. No. 4,670,364; Issued 6/2/87*  
**Photomask for Electrophotography**  
*Inventor: VICTOR C. HUMBERSTONE*  
*Assigned to: COMTECH RES. UNIT LTD.*

A master for use in image transfer by contact printing onto a transparent electrophotographic (TEP) film comprised of an electrically insulating substrate having a planar surface carrying image elements deposited thereon; and a thin transparent insulating layer covering said planar surface and said image elements is described. The surface of the thin transparent insulating material is preferably profiled so that it comprises a base level and raised portions extending above said base level, the area of the raised portions being small compared to the total surface area of the transparent insulating layer. A thin transparent electrode may be incorporated between the substrate and the thin transparent insulating layer. Methods of forming such a master and of contact printing with it are also disclosed.

*Used with permission of IFI/Plenum Data Co.*

*U.S. Pat. No. 4,669,857; Issued 6/2/87*  
**Double-Dual-Rate Precision Scan System**

*Inventors: DANIEL W. COSTANZA,  
EDWIN F. GLAB, RICHARD A.  
SPINELLI, WILLIAM L. STATT*

An electrophotographic printing system incorporating two sets of moving optical components, one on each side of a projection lens is disclosed. A document on a platen is scanned by a first set of moving mirrors with the scanned image projected by a lens towards a photoreceptor. A second set of moving mirrors precesses the image onto the photoreceptor. In one embodiment, a drive system commonly drives both the object side and the image side mirrors to provide the required document scan and precess motions. In a second embodiment, the image side system is driven as a function of the photoreceptor (process) speed.

*U.S. Pat. No. 4,672,264; Issued 6/9/87*  
**High-Contrast Electroluminescent Display Panels**

*Inventor: MALCOLM H. HIGTON*  
*Assigned to: PHOSPHOR PRODUCTS CO., LTD.*

A dc or ac electroluminescent panel comprising a transparent substrate, a transparent first electrode film, a thin-film phosphor layer, a control layer, and a second electrode film is described. A black or dark-colored material, less than 1  $\mu\text{m}$  thick, is interposed between the thin-film phosphor layer and the control layer to enhance the contrast of the panel whenever a voltage is applied across the thin-film phosphor layer causing it to emit light.

*U.S. Pat. No. 4,672,177; Issued 6/9/87*  
**Environmental Sensor Control of a Heated Fuser**

*Inventor: MICHAEL R. HEADRICK*  
*Assigned to: IBM CORP.*

The quality of toner fusing in an electrophotographic or xerographic copier or printer is improved by modifying the reference voltage employed, in conjunction with the fuser hot-roll temperature sensing, with a factor correlated to the temperature sensed in the environment of the fuser assembly. In a typical embodiment, the environment temperature is used to develop the reference voltage applied for comparison with the signal from a direct hot-roll temperature thermistor. Thus, the temperature set point toward which the hot roll is driven varies as a function of the environment temperature for the fuser assembly.

*U.S. Pat. No. 4,673,929; Issued 6/16/87*  
**Circuit for Processing Digital Image Data in a High-Resolution Raster Display System**

*Inventors: EDWARD T. GROSSHEIM,  
JOHN E. NELSON, FRANKLIN M.  
PERELMAN*  
*Assigned to: GOULD INC.*

A high-resolution raster display including a central processor for providing image data, a digital image-processing circuit for converting the image data to display signals, and an analog display circuit for converting the display signals to drive signals for driving a CRT to form a color raster display on the screen of the CRT is described. The digital image-processing circuit includes a display memory for storing the image data and a programmable attribute look-up table for storing attribute data. Under the control of the central processor, the image data stored in the display memory is read out and is used to address the attribute look-up table which provides attribute signals as an output. A pixel rate converter reads in the attribute signals at a first rate and outputs analog display signals at a second rate which is much higher than the first rate, with a video bandwidth of up to 210 MHz. The display signals are received by the analog display circuit, and are used to generate drive signals for driving the color guns of the CRT. The central processor is also capable of providing intensity control signals to the analog display circuit so that the intensity level of each of the attributes identified by the attribute signals can be varied. In this manner, the intensity of the various types of features on a display (for example, background, map, weather, flight path, etc.) can be varied independently.

*U.S. Pat. No. 4,673,627; Issued 6/16/87*  
**Electrophotographic Lithographic Printing Plate**

*Inventors: YASUZI ASAO, YOSHIKAT-SU KAGAWA, KENJI  
KUNICHIKA, SHO NAKAO,  
CHIKASHI OHISHI*  
*Assigned to: FUJI PHOTO FILM CO., LTD.*

An electrophotographic lithographic printing plate is described, comprised of an electrically conductive support and a photoconductive layer on the support, said layer being made mainly of a photoconductive zinc oxide and a resin binder, wherein in the surface of the photoconductive layer the degree of exposure of photoconductive zinc oxide is from 10% to 70%.

U.S. Pat. No. 4,674,108; Issued 6/16/87

### **Digital X-Ray Medical Diagnostic Apparatus**

*Inventors: HIROSHI ASAHINA,  
ICHIRO OGURA*

An x-ray photographing device of a digital fluorographic apparatus for use in x-ray diagnosis including an image intensifier for converting x-rays transmitted through an object to an optical image, and a TV camera for converting the optical image to a television video signal is described. An effective video-level range of the TV camera is narrower than that of the image intensifier. In order to perform a proper x-ray transmittance correction for the object, an x-ray television video signal is converted, at levels out of the effective video level range of the TV camera, to a maximum allowable input video level. In a TV monitor, the levels of the television signal which are out of the effective video-signal-level range of the TV camera are displayed at the maximum signal level to permit a ready transmittance correction operation. The subtraction image is displayed in accordance with the proper corrected levels.

U.S. Pat. No. 4,675,833; Issued 6/23/87

### **Processor-Controlled Photocomposition System**

*Inventors: CHRISTIAN BOURDIN,  
THOMAS B. CHEEK*  
*Assigned to: XYVISION INC.*

A photocomposition system operating under microprocessor control to load, and alternatively display, character data from two respective bit maps is described. The data is assembled in the bit maps as a series of vertically adjacent video words generated from font data stored as a series of character boundary points and loaded into the bit maps in a controlled fashion to avoid destructive interference with image data already stored in the bit maps. Data in the bit maps can be displayed either on a CRT or via a laser printer or photocomposition system. System memory includes a plurality of fonts of data in which the characters are segmented into short segments and the boundary points thereof digitally recorded. From the recorded points, a curve fit of an arc section is used to define the complete character boundary for each segment, and video data words are generated to indicate the boundaries on the vertical segments of the character defined by the arc sections fit to the recorded points. This video data is then applied to an image processor. While one bit map is

used to generate display information, the other is loaded with each incoming video data word by cycling bit-map data through an arithmetic logic unit controlled by the image controller to prevent newly inserted data from destructive interference with data already assembled in the bit map.

U.S. Pat. No. 4,676,923; Issued 6/30/87

### **Dichroic Dyestuffs for Liquid-Crystal Composition**

*Inventors: SEIKO KOBAYASHI,  
MASASHI ONO, SHIGEO SENZAI,  
TATSUO UCHIDA, SHIGEO  
YASUI*

*Assigned to: KABUSHIKI KAISHA NIP-  
PON KANKO SHIKISO  
KENKYUSHO*

New dichroic dyestuffs for the guest-host-type liquid-crystal and new liquid-crystal compositions containing said dyestuff are described. These compositions have an excellent improved dichroism and are prepared by introducing at least one group selected from the group consisting of phenyl, cyclohexyl, phenylcarbonyloxy and phenyloxycarbonyl group into a phenyl, a cyclohexyl or a naphthyl group at its 4-position, and arranging it at the end of a known dichroic dyestuff molecule along the major axis of the molecule.

U.S. Pat. No. 4,680,635; Issued 7/14/87

### **Emission Microscope**

*Inventor: NEERAJ KHURANA*  
*Assigned to: INTEL CORP.*

An emission microscope providing time resolution and high sensitivity to the viewing of light emitted from semiconductor devices is described. The present invention comprises a microscope optic system coupled to an image intensifier. An integrated circuit is viewed with the microscope optics and is stimulated with current flow. As a result of different phenomena (oxide current, avalanching, and forward biased p-n junctions), light is emitted from the circuit. The image intensifier magnifies the light signal produced by the microscope optics. The output of the intensifier is coupled to a solid-state (CID or CCD) camera. The CID camera outputs a TV signal which is coupled to an image-processing computer. The image-processing computer controls image enhancement as well as noise reduction. The image-processing computer is coupled to an output such as a monitor, a recorder, a printer, or any other suitable display.

U.S. Pat. No. 4,678,284; Issued 7/7/87

### **Antiflocculating Agent for Spacers in Liquid-Crystal Displays**

*Inventor: YOSHIZO TASHIRO*  
*Assigned to: ALPS ELECTRIC CO.,  
LTD.*

A liquid-crystal display composed of two sheets of plastic film, two transparent electrodes respectively formed on one side of the sheets and opposed to each other with spacer powder between them, and liquid-crystal material sealed-in between the electrodes is disclosed. The spacer powder is coated with a hot melt adhesive, such as vinyl acetate adhesive or polyethylene adhesive, by adding an antiflocculating agent, such as polyethylene wax, and spacer powder, such as aluminum oxide, to suspension of the hot melt adhesive, and then drying the suspension. The resultant powder is fixed to the sheets by the adhesive.

U.S. Pat. No. 4,680,580; Issued 7/14/87

### **Active-Matrix-Addressed Liquid-Crystal Display Device**

*Inventor: YUKITO KAWAHARA*  
*Assigned to: DAINI SEIKOSHA*

An active-matrix-addressed liquid-crystal panel comprising plural matrix picture elements is disclosed. The defects of a picture caused by a short between a row electrode and a substrate is inconspicuous because each row electrode controls the picture elements belonging to the row as well as the picture elements belonging to the neighboring rows.

U.S. Pat. No. 4,678,961; Issued 7/7/87

### **Projection Television Display Tube with Improved Cooling**

*Inventors: ALBERT A. COMBERG,  
JOHANN SCHRODER*  
*Assigned to: U.S. PHILLIPS CORP.*

A description of a projection television display tube is given comprised of an evacuated envelope having a display window on its inside with a display screen, a transparent second window which is disposed in front of said display window on its outside, and a transparent coolant flowing through the space between the display window and the second window, said coolant conveying the heat taken up at the display window through a cooling member to the atmosphere. The coolant is also in thermally conducting contact with a latent heat accumulator, so that an effective cooling is obtained even at peak loads of more than 40 W, and without external pipes.

## patents

*U.S. Pat. No. 4,679,069; Issued 7/7/87*  
**Color-Picture Projection System with a Wavelength-Selective Reflector for Filtering out Undesired Light from a Monochrome Picture Display Source**  
*Inventors: JOHAN ANDREA, RALPH H. BRADLEY, EUGENE LUBCHENKO*

A color-picture projection system comprised of three superimposed monochrome pictures forming a color display on a projection screen by means of a chromatic projection lens system in each of three channels is described. Each channel has a reflector to fold the light path. Since at least one monochrome picture (e.g., the blue picture) includes radiation within a desired band of wavelengths corresponding to its associated color and radiation outside of this desired band, the reflector in this channel is wavelength selective and reflects only the radiation within the desired band towards the projection screen. The undesired radiation is transmitted through the reflector so that it does not reach the projection screen. Achromatic lenses are therefore not required.

*U.S. Pat. No. 4,680,579; Issued 7/14/87*  
**Optical System for Protection Display Using Spatial Light Modulator Device**  
*Inventor: GRANVILLE E. OTT*  
*Assigned to: TEXAS INSTRUMENTS INC.*

A projection display employing a light source, a spatial light modulator such as a deformable mirror device having a plurality of individually electrically deformable mirror cells and Schlierin optics to project light from deformed mirror cells onto a viewing screen is described. An optical system forms light from the light source into a substantially collinear beam. A Schlierin optical device composed of alternating reflecting and transmitting portions is disposed at an angle to this beam. Light reflected or transmitted by the Schlierin optical device is focused by additional optics to a point near the deformable mirror device. Light reflected from undeformed mirror cells passes through the Schlierin optical device back to the light source. Deformed mirror cells reflect light at least in part to differing portions of the Schlierin optical device to follow a different path to the viewing screen. Control of the deformation of individual mirror cells thus enables control of illumination of corresponding spots on the viewing screen. A color picture may be formed using multiple deformable mirror devices and color filters. A three-

dimensional image may be formed using multiple projection systems and a directionally reflecting screen or polarizing filters for differing deformable mirror devices with matching polarizing glasses.

*U.S. Pat. No. 4,678,285; Issued 7/7/87*  
**Liquid-Crystal Color Display Device**  
*Inventors: TAKAMICHI ENOMOTO, WASABURO OHTA, KIYOHIRO UEHARA*  
*Assigned to: RICOH CO., LTD.*

A liquid-crystal color display device for displaying a color image represented by an applied image signal, including a liquid-crystal cell, one or two polarizers, and a fluorescent light-emitting means is described. The liquid-crystal cell and one polarizer disposed on one side thereof, or the liquid-crystal cell and the two polarizers sandwiching the same, jointly constitute a switching element responsive to the image signal applied to the liquid-crystal cell for passing electromagnetic radiation in a pattern representing the image given by the image signal. The fluorescent light-emitting means has a fluorescent layer and a lamp for generating electromagnetic radiation, and may additionally include a color filter. The fluorescent layer is responsive to the electromagnetic radiation from the lamp for emitting chromatic fluorescent light. Where the fluorescent light-emitting means has the color filter, the fluorescent light passes through the color filter to display the image.

*U.S. Pat. No. 4,679,043; Issued 7/7/87*  
**Method of Driving Liquid-Crystal Matrix Display**  
*Inventor: SHIGERU MOROKAW*  
*Assigned to: CITIZEN WATCH CO., LTD.*

A drive method for a liquid-crystal matrix display panel is disclosed whereby the display is driven as two or more separate regions, with each region being successively driven by row and column drive signals to display video data in a row-by-row manner during a drive phase; the remaining regions operate in a rest phase in which a potential substantially equal to zero is applied across the display elements of these other regions. The effective number of row electrodes to which sequential scanning signal pulses are applied, which determines the level of contrast obtainable with such a display panel when the number of display elements is large, is made equal to the number of row electrodes of each of these regions, so that a sufficiently high number of elements for high-resolution television display is attainable with a

simple display panel and peripheral circuit configuration.

*U.S. Pat. No. 4,680,643; Issued 7/14/87*  
**Image Display Apparatus**  
*Inventor: TOSHIO HORIGUCHI*  
*Assigned to: OLYMPUS OPTICAL CO., LTD.*

An image display apparatus is described for storing segment addresses of a plurality of selected image data and selectively removing segment addresses and forming addresses of an image memory of one picture plane on which those plurality of image data are combined and displayed. The segment address storing means is constituted by address registers which are cascade connected. The image memory address forming means is constituted by means of adding the selected segment address data and an output of a pixel counter.

*U.S. Pat. No. 4,680,578; Issued 7/14/87*  
**Baseline Transposition and Character Segmenting Method for Printing**  
*Inventors: KLAUS-JUERGEN HORNIG, HANS-HENNING THIESSEN*  
*Assigned to: MERGENTHALER LINOTYPE GMBH*

A description of characters encoded in digital data, which is used to modulate a display to image the characters is given. Characters are typically displayed on a display baseline which corresponds to the physical character baseline encoded in data. Where the distance of a character from its physical baseline in a first dimension exceeds the boundary limit of a display, the location of the character baseline and the display physical baseline corresponding thereto may be shifted in the opposite direction and in the same dimension in extent equal to the amount said character exceeds the display and until the character fits within the display. Alternately, where the character at its display size is larger than the display in any display dimension, the character may be segmented into parts and logical baselines inserted into each separate section. These logical baselines may be referenced to the character physical baseline relative to the distance in a first dimension there between. Accordingly, the logical baseline may be referenced to the character physical baseline and the display baseline to appropriately locate the character relative to the physical baseline, so that when the separate sections are reassembled on the display, the original character is reproduced.

*U.S. Pat. No. 4,680,626; Issued 7/14/87*

### **Color-Image-Processing System for Converting Analog Video-to-Digital Data**

*Inventors: GALEN COLLINS,  
MICHAEL F. DEERING  
Assigned to: BENSON INC.*

A color image-processing system is described which provides more realistic hard-copy color images from composite video system input signals than previously available. The image-processing system includes a synchronization separator 20 which operates to separate the synchronization pulses from the analog video information supplied to it. The analog video information is then converted to digital form by an analog-to-digital converter. The converter operates under control of a time base generator 100, including a programmable delay line 300, which receives synchronization pulses from the synchronization separator, and following a programmable time delay supplies a control pulse to the converter to cause it to sample the analog waveform and convert it to digital format. Once the signal is digitized, it is converted from an additive color system to a subtractive one end enhanced before being supplied to the color plotter 8.

*U.S. Pat. No. 4,679,909; Issued 7/14/87*  
**Liquid-Crystal Input/Output Matrix Panel**

*Inventors: FUMIAKI FUNADA,  
HIROSHI HAMADA, MASATAKA  
MATSUURA  
Assigned to: SHARP CO.*

Numerous photoelectric translation cells are arranged to correspond to associated picture elements in an active-matrix LCD system. When a light pen is used as an input means, the system allows detection of light-beam positions, enabling it to function as an input means. The liquid-crystal input/output system constructed in this manner has advantages of low power consumption and thin and lightweight construction as compared with conventional input/output systems using a combination of CRT and light pen. It is best suited for applications in portable electronic appliances and offers great technical benefit by arranging the photoelectric translation cells in a manner so as to increase the aperture ratio of the matrix display.

*U.S. Pat. No. 4,680,599; Issued 7/14/87*

### **Cathode-Ray-Tube Display System and Method Having Bidirectional Line Scanning**

*Inventors: JAMES H. ORSZULAK,  
CHRISTOPHER L. SWEENEY,  
RONALD D. WERTZ  
Assigned to: BALL CORP.*

A CRT display system and method having bidirectional line scanning are disclosed. Bidirectional line scanning is achieved by scanning each odd-numbered scan line from left to right and each even-number scan line from right to left, thereby avoiding the necessity for retrace, or flyback. In order to avoid loss of intelligibility in displaying the video information received from a conventional source providing video information written only from left to right, as is conventional, the received video information is stored in memory by scan lines with each odd-numbered line being read out in the same order as stored in memory and each even-numbered line being read out in reverse order as stored in memory. Timed control is provided for processing of the video information and display thereof with bidirectional scanning, and geometric error correction is provided for both the horizontal and vertical scan generators.

*U.S. Pat. No. 4,680,631; Issued 7/14/87*

### **Television Composite Video-Signal-Processing Circuit**

*Inventors: TADAO MIYABAYASHI,  
MOTOI YAGI  
Assigned to: TOKYO ELECTRIC CO.  
LTD.*

A television composite video-signal-processing circuit with a readout circuit for repeatedly reading out a one-field composite video signal from a disk memory is described. A delay circuit delays the composite video signal from the readout circuit by one-half of a horizontal sync signal period, and a pedestal clamping circuit sets the pedestal levels of the composite video signals from the delay circuit and the readout circuit to a predetermined level. A signal selector alternately supplies the composite video signals from the readout circuit and the delay circuit to the pedestal clamping circuit for every other field, and a peak-level correction circuit corrects the peak level of the delayed video signal in the delayed composite video signal from the delay circuit. The peak-level correction circuit corrects the peak level of the delayed video signal so as to match this peak level with that of the nondelayed video signal from the readout circuit in accordance with a

peak-level difference between the delayed and nondelayed video signals.

*U.S. Pat. No. 4,680,630; Issued 7/14/87*  
**Apparatus for Processing Digital Video Signals to Produce a Television Image by Line and Field Sequential Scanning**

*Inventor: ANTHONY J. FIELD  
Assigned to: U.S. PHILLIPS CORP.*

An arrangement for rotating television pictures is described comprising a frame store into which a rotated input picture is written under the control of a write address generator which is in turn controlled by a rotation control and timing generator. A video input signal is applied at input and fed to a splitting circuit which produces streams of even and odd numbered samples, both at the sampling rate. These streams of samples are fed to an interpolator where they are used to generate samples to be written into the store. The store is split into four areas which are arranged to hold, respectively, field 1 odd samples, field 1 even samples, field 2 odd samples, and field 2 even samples. The write address generator is controlled so that samples from field 1 of the input signal are fed only into the areas of the store read by the read address generator during field 1 of the output signal and samples from field 2 of the input signal are fed only into the areas of the store read by the read address generator during field 2 of the output signal.

*U.S. Pat. No. 4,680,632; Issued 7/14/87*  
**Television Display System with Flicker-Reduction Processor Having Burst Locked Clock and Skew Correction**

*Inventors: TODD J. CHRISTOPHER,  
RUSSELL T. FLING, DONALD H.  
WILLIS  
Assigned to: RCA CORP.*

A speed-up memory doubles the field rate of a video input signal by repeating each field to reduce flicker when the double field rate signal is displayed. Read/write clocks for controlling the memory are locked to the color subcarrier of the video input signal thereby tending to produce visual artifacts in the displayed image due to clock skew relative to sync when nonstandard video signals are processed. The skew errors are corrected by circuitry which measures the skew of the read and write clocks and delays the video signal as a function of a difference between the clock skew measurements. ■

### Color LC imager works with overhead projector

Telex Communications, Inc., introduces the MagnaByte 5220-I, reported by its manufacturer to be the first electronic imager to display color. The MagnaByte 5220-I consists of a special LCD palette that fits on the top of any standard overhead projector, an interface card which inserts into a personal computer, and a hand-held remote control. When the palette and remote control are connected to the interface card and the computer turned on, a colorful depiction of any text or graphic on the computer's display screen is projected onto the wall. The new system can be used with IBM PC/XT/ATs and most IBM compatibles such as Telex Intelligent Workstation, and can also be used with color as well as



monochromatic computer systems. Suggested retail price for the MagnaByte is \$1580.

For further information contact Daniel Paulnock, Telex Communications, Inc., 9600 Aldrich Ave. So., Minneapolis, MN 55420. 612/884-4051.

Circle no. 5

### Portable compact still-image recorder/player

Sony Information Systems' compact ac/dc powered industrial still image player/recorder is the first still video deck able to record time-compressed audio along with images. Using industry-standard 2-in. video floppy disks, the MVR-A770 can record up to 50 fields or 25 frames with a horizontal resolution of 360 TV lines. A built-in shuttle dial provides quick image access, and allows 8 frames/revolution. Frames/fields can be recorded, erased or accessed sequentially or at random. In the autoplay mode, playback speed can be adjusted to 5, 10, or 20 sec/image. The deck is capable of recording a maximum of 9.6 sec of digitally compressed FM audio with every 16 frames or 25 fields, or a total of 500

# Compact. Remote. Resolution.







sec at 9.6 sec/track. Designed for indoor and location operation, the MVR-A770 deck runs approximately 1 hour on an NP-1A rechargeable battery or can be powered by an ac pack or dc input. The unit measures 335 mm (W) × 230 mm (D) × 77 mm (H), and is priced at approximately \$3000.

For further information contact Ziya

Oz, Sony Corp. of America, 9 W. 57 St., New York, NY 10019. 212/575-1976.  
Circle no. 6

### Touch-screen switch

C.A.M. Graphics' clear Touch-View screen is specifically designed for use as a transparent switch or control element for direct placement over CRT screens, alphanumeric readouts, or backlit displays. Touch-View switches can be placed in any location specified along the X-Y axis of the screen with spacing typically 0.5 in. between centers. The Touch-View screen can also be made into a linear control element with almost infinite resolution. Applying pressure in different areas of the linear screen will result

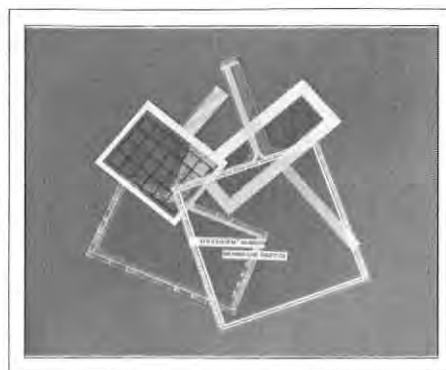

in different resistance values. Combinations of fixed-position switches and linear control devices can be supplied on the same screen; tinted or colored "windows" can also be incorporated into the screen. Touch-View screens have been tested for over one million actuations and can be made to various military specifications for

## TRUST WESTINGHOUSE TO GIVE YOU THE UTMOST IN 1" MONITOR FLEXIBILITY AND RELIABILITY.

Performance capability and configuration flexibility: the new Westinghouse MHR-1100 1-inch CRT monitor puts them together like never before. And that opens a whole new level of application possibilities for you.

We start with high resolution (800 TV lines). Then we add remote flexibility. The tube and the electronics can be as far as six feet apart. That makes it easier than ever to use it in many applications from tank

sights to aircraft displays.

For even more flexibility, the controls for brightness and contrast can be placed remotely. We can custom-alter the shape to fit your requirements.



The monitor is designed for high reliability (MTBF) in rugged military environments—a wide supply power range of 18 to 32 VDC, low input power requirements—just 10 watts at 18 VDC. It operates over temperatures from minus 40 to plus 71°C, and withstands shock

and vibration.

The fact is: no other 1-inch CRT monitor combines such high levels of performance with remote configuration flexibility the way the MHR-1100 does. Let us help you design it into your system.

Just write or call. Westinghouse Electric Corporation, Imaging & Sensing Technology Division, Westinghouse Circle, Horseheads, NY 14845. (607) 796-3350. TWX 510-252-1588. FAX (607) 796-3279.



**You can be sure...  
if it's Westinghouse**

Circle no. 7

## new products

ground or airborne applications. The polyester film substrate material enables it to be applied flat or curved to conform to equipment configurations. Price is \$55-500, according to quantity and specifications.

For further information contact Tracy De Iorio, C.A.M. Graphics Co., Inc., 15 Ranick Dr. W., Amityville, NY 11701. 516/842-3400.

Circle no. 8

## Rugged miniature impact printers

A line of rugged low-cost miniature printers for industrial, laboratory, and medical applications has been introduced

by Keltron Corp. The Keltron Miniprinter series incorporates Centronics compatible, RS-232C, RS422, 20 mA or parallel BCD

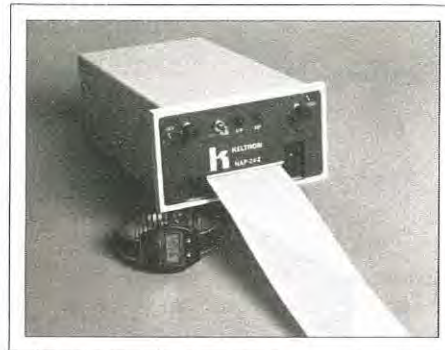

interfaces. The impact printers use plain paper and ink ribbon cartridges, and are available in 16-, 24-, 32-, and 40-column

formats. The series requires 5 VDC power, and ASCII models have a 2K character buffer. The printers are available in a 4.45 in. (W) × 8 in. (D) panel-mounted/table-top metal case or kit and sub-assembly form. Optional features include an internally mounted paper takeup, battery backup clock, 8K character buffer ASCII models, and 120 VAC, 220 VAC or 9-40 VDC power supplies. Privately labeled miniprinters and sub-assemblies are also available. Prices start at \$395 for 16-column ASCII models in single quantity, and quantity discounts are also offered. Custom models quoted upon request.

For further information contact Chris Szmauz, Keltron Corp., 225 Crescent St., Waltham, MA 02154. 617/894-8700.

Circle no. 9

# HYCOM TFEL DISPLAY SYSTEMS

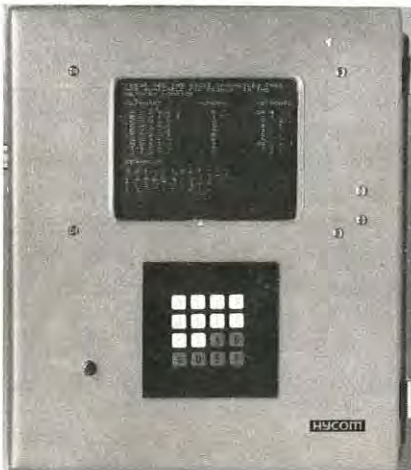

DATA  
BASE



SHADED  
VIDEO



The VU-100 DISPLAY gives 16 shades of video picture on a TFEL screen (4.72 × 3.54 in.). This unit is very compact (7.25 × 6 × 1.5 in.), light (2.5 lbs.), and low-power (20 watts). Input signal is broadcast TV, CCTV, or VCR (RS-170).

NETWORK MONITORS display computer data at remote locations. The host computer can service up to 64 monitors (RS-232/RS-244). A local keypad requests data and selects desired page for display. Local memory holds three pages. TFEL page matrix can be 320 × 240, 512 × 256, or 640 × 200. Self-powered; NEMA enclosure; output for serial printer.

## HYCOM

16841 Armstrong Ave., Irvine, CA 92714-4979

(714) 261-6224

Circle no. 10

### A 1-in. military CRT display

A compact high-resolution military display with a 1-in.-diameter CRT is now available from Westinghouse Electric

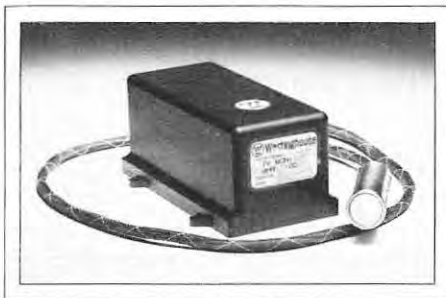

Corp. The MHR-1100 monitor is one of the smallest available military CRT

displays in the industry. The complete monitor with tube measures  $3 \times 3 \times 7$  in. The optional MHR-1100XR can be ordered with the encapsulated tube at the end of a 6-ft. cable, so that use of panel space can be minimized. A 1.5-in. diagonal display is also available. Both configurations have a wide input power range of 18-32 VDC plus RS-170 or CCIR video format. Contrast and brightness controls can be located as far from the electronic circuitry as design demands, with no loss of bandwidth and no EMI complications.

For further information contact Westinghouse Electric Corp., Industrial and Government Tubes Div., Westinghouse Circle, Horseheads, NY 14845. 607/796-3350.

Circle no. 11

### HDTV camera tube

The Thomson-CSF TH X898 camera tube is designed specifically for upcoming high-definition TV (HDTV) standards. The

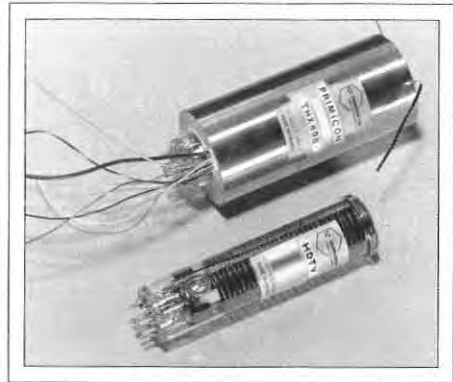

## MINOLTA METERS THE MEASURE OF EXCELLENCE

© 1987 Minolta Corporation

### FOR ACCURATE NON-CONTACT COLOR MEASUREMENT, NO OTHER METER COMES CLOSE.

Minolta's new CS-100 Chroma Meter achieves precision and comes close to everything else. Everything else, that is, in the way of light sources or surface colors that you might otherwise find difficult to measure.

Just point it and instantaneously read the luminance value of light sources or objects which are either too hot, too distant, too small, too inaccessible or for any reason simply not to be touched. Our spot colorimeter's built-in memory will also give you the difference between any two such sources or objects automatically.

And the CS-100 is just one of Minolta's full line of light and color measurement instruments. For more information, including our 21 page booklet "Precise Color Communications," please call (201) 825-4000 or write: Minolta Corporation Industrial Meter Division, 101 Williams Dr., Ramsey, New Jersey 07446.

When you need precise measurements, you just can't touch it. **ONLY FROM THE MIND OF MINOLTA.**



MINOLTA

Circle no. 12



## new products

tube uses a 1-in. Primicon photoconductive layer, making it well suited for three-tube color cameras. The gun employs an advanced electrostatic deflection,

magnetic focus design, and has a dispenser-type cathode to ensure long life. The TH X898 incorporates its own focusing coils,  $\mu$ -metal shielding and an LED

bias light. Signal output is from a target contact (capacitance less than 5 pF). Essential performance figures include a contrast transfer function of at least 40% at 700 TV lines ( $7.84 \times 13.95$  mm scanning format), with a limiting resolution of approximately 1800 pixels/line. Light sensitivity for W/R/G/B illumination is, respectively, 450/120/155/80  $\mu$ A/lum. Lag after 60 msec (100-nA signal with bias light) is on the order of 1%. The TH X898 is at a final development stage, and samples will be available by the end of 1987.

For further information contact Thomson Tubes and Electron Devices Corp., 550 Mount Pleasant Ave., P.O. Box 6500, Dover, NJ 07801. 201/328-1400.

Circle no. 14

# Hughes

## Electro Optical Engineer

Hughes Aircraft Company, the world leader in high technology electronics, is currently seeking Optic Engineers for White Sands, New Mexico and the Los Angeles area.

### Optics Engineers High Energy Laser System White Sands, NM

Will provide engineering analysis and technical services on fluid cooled optics, low power optics and optical beam diagnostic instrumentation equipment for a high energy laser system.

### Display Optical Engineers Aircraft Simulator Program Los Angeles Area

Coordinate design, manufacture and test functions, and integrate wide angle projection lenses. We prefer 5-10 years experience in optical engineering. Should be experienced in developing requirements for lens designers. Background in mechanical engineering and/or control systems highly desirable.

### Manager of Systems Development

You will perform systems engineering analysis related to proprietary computer image generation programs, oversee hardware and software integration matching program and customer requirements, assist

in defining product configuration including application of photogrammetric techniques to development of requisite landmass data bases and prepare proposals and competitive analysis.

An advanced EE degree and extensive experience in computer generated imagery preferred. Demonstrated strength in customer interface, ability to translate customer requirements to product definition and development of proposal responses desirable.

We offer an attractive salary and outstanding benefits package.

Please send your resume to: Lowell Anderson, Hughes Aircraft Company, Support Systems, Dept. DI-1087, P.O. Box 9399, Long Beach, CA 90810-0463. Proof of U.S. citizenship required. Equal Opportunity Employer.

**MODEM USERS:** Access our online Career Center by computer for further information regarding our many job opportunities. Call (a modem only) (213) 372-4050. Type GO HUGHES upon entry.

**Creativity  
America depends on.**

**HUGHES**  
AIRCRAFT COMPANY  
SUPPORT SYSTEMS

## LED lamps and displays

Hewlett-Packard announces a new family of LED indicators and displays based on double-heterojunction aluminum and gallium arsenide (DH-AlGaAs) technology. The high-brightness lamps typically provide between 185% and 700% more light output than existing HP high-efficiency red LEDs at 20 mA. The low-current lamps, specified at 1 mA, have typical intensities between 2 and 10 mcd, making them 2.5-12 times brighter than HP's present low-current LEDs. Two very high brightness LEDs have a narrow viewing angle of approximately  $8^\circ$  that maximizes on-axis intensity to 750 and 1000 mcd. The seven-segment displays are available in four sizes: 0.3 in./7.6 mm, 0.43 in./10.9 mm, 0.56 in./14.2 mm, and 0.8 in./20 mm. All of the new LED lamps provide an operating temperature range of  $-20$  to  $+100^\circ\text{C}$ ;

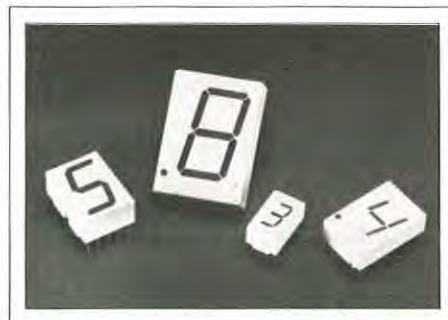

Circle no. 13

the display products have an operating temperature range of  $-20$  to  $+85^{\circ}\text{C}$ . AlGaAs products are available only in red. According to quantity, prices range from  $\$0.34$  to  $\$3.06$  ea.

For further information call the Hewlett-Packard Company sales office listed in the white pages telephone directory.

Circle no. 15

### LCD bargraph module

UCE, Inc. announces a new vertical bargraph with 1% accuracy and high and low set points displaying analog value and trend information. Model IDA-2-100B offers low and high set point alarm limits. An alarm output is also available for an over range condition, and limit setpoints can be set by an external switch or a microprocessor. A/D conversion can also be read by a microprocessor. All inputs to the module are isolated using electro-optic couplers. The module operates from a 9-V battery or a variety of power sources. A transfective backing for bright, ambient, and complementary backlighting for dim/dark light makes the LCD highly readable under any lighting conditions. An analog-digital module with the same electronic capability is scheduled for the fourth quarter of 1987, and will show analog and simultaneous digital values for



both trend and four-place digital accuracy. The module is  $2.1 \times 5.8$  in., with a  $5 \times 0.5$  in. LCD. The cost is  $\$229.90$  ea. at 100 pieces.

For further information contact Dick Borstlemann, UCE Inc., 24 Fitch St., Norwalk, CT 06855. 203/838-7509.

Circle no. 16

## Avoid Shocking Disconnects!

Protect your CRTs from unexpected disconnects. Specify our **CRT SOCKETS** with exclusive Tube Neck Retaining Clamps.

### Quality features make Quality CRT Sockets . . .

- Non-conductive, 94V-O Tube Neck Retaining Clamps.
- Rugged and resilient assembly.
- Protective Spark Gaps.
- In-line Components available.
- Tapered lead-ins for easy insertion.
- Wrap-around Contacts for low resistance.
- Quality sockets your way, prototype to production.

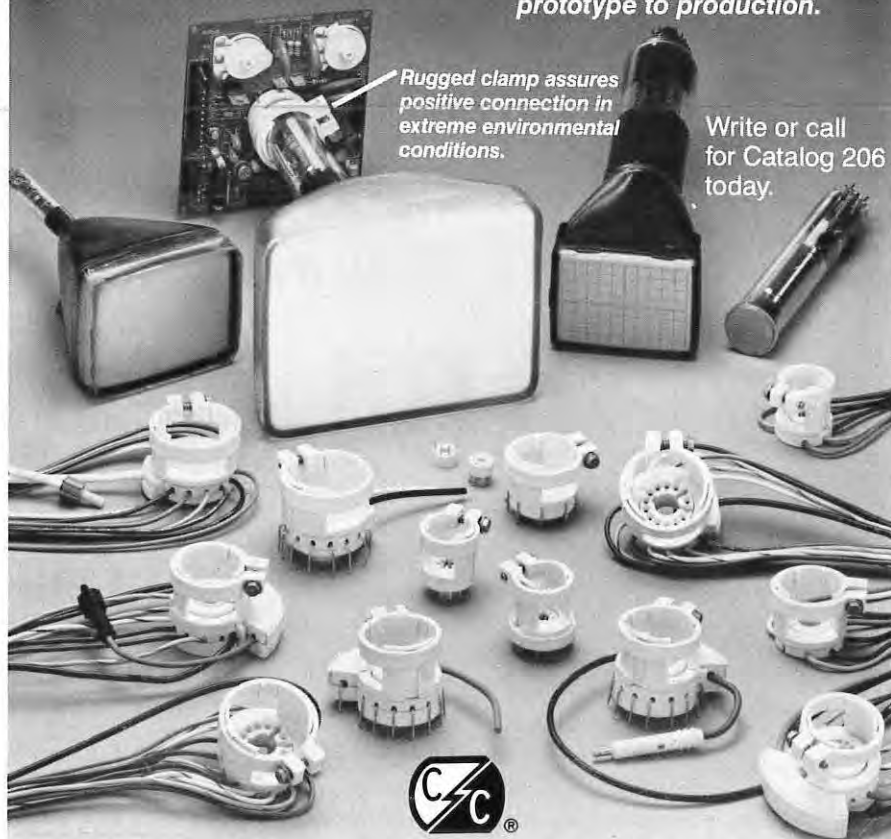

Write or call for Catalog 206 today.



## CONNECTOR CORPORATION

6025 N. Keystone Ave. • Chicago, IL 60646-5290 • 312/539-3108 • TWX 910-221-6059

Circle no. 17

---

## new products

---

### LED displays

A line of high-quality LED lamps and displays is now available from Hunter Components. The displays include a wide variety of sizes and colors in 7-segment displays for numeric readouts, as well as 15-segment and dot-matrix displays for alphanumeric readouts. Colors include red, high-efficiency red, orange, green, and yellow. LED clock displays and clock display modules, LED lamps, infrared lamps, and photodetectors are also available. Hunter also offers custom-designed displays and complete display modules. Hunter is the exclusive U.S. marketing representative for Toptek Electronics Co., Ltd., Taiwan. Typical prices of Hunter LED displays in quantity are \$0.56 for a 0.3-in.-high 7-segment display



and \$2.48 for a 2-in.-high 5 × 7 dot-matrix display. In volume, LED lamps start at \$46 per thousand.

For further information contact Hunter Components, 24800 Chagrin Blvd., Suite 101, Cleveland, OH 44122. 216/831-1464. **Circle no. 18**

---

### Plasma panel module

A new 240-character dot-matrix plasma panel display module complete with drive electronics designed for easy interfacing with CRT controllers is now available from Dale Electronics, Inc. The APD-240M026A panel displays six lines of 40 characters each. Each character measures 0.14 in. (W) × 0.26 in. (H) in a 5 × 7 dot-matrix format. The APD-240M026A has overall dimensions of 4.30 in. (H) × 11 in. (L) × 1.21 in. (D). Viewing area is 2.26 in. (H) × 8.33 in. (W). High brightness (100 fL) and a wide viewing angle (150°) make the panel ideal for many applications. It is easily interfaced with CRT controllers, or if required, can be provided with a controller board which has parallel and RS232

---

**When you need high-voltage power supplies for  
LASER, CRT, PMT, IMAGING TUBE and X-RAY systems,  
we'll design, produce and deliver prototypes within**

# 61 days

Custom designs to suit your application are our business. With experienced people and ample quality-controlled facilities, we go all-out to meet your new-project schedules.

Production quantities of your high-voltage power supplies can be ready within 90 days of prototype approvals. You don't have to put up with delays to get high-quality, reliable components for your systems. Give us a call.

**Call 1-203 792-7820**

**International  
High Voltage  
Electronics, Inc.**

**Finance Drive Danbury, CT 06810**

Circle no. 19

ASCII inputs (Model APD-240M026A-1). The APD-240M026A costs \$480 ea. in quantities of 100.

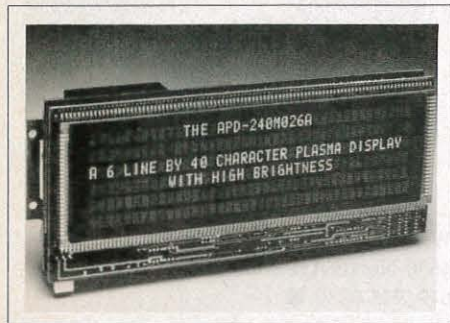

For further information contact Margaret Nowicki, Dale Electronics, Inc., 2064 12 Ave., Columbus, NE 68601. 402/564-3131. Circle no. 20

### Versatile EL lamps

Bell Industries has developed a line of EL lamps 0.090 in. thick with sufficient light output to illuminate aircraft cockpit instruments. When activated by 115 VAC, the phosphors in these "cards" luminesce, providing light of various colors. The individual EL lamps measure 3.50 x 5.25 in., and with a typical current draw of 2 mA/in.<sup>2</sup>, they can be used where incandescent lamps and LEDs are not practical. Bell Industries' EL lamps are available as bare lamps, in lightplates, or in integrated switch panels.

For further information contact Bell Industries, Illuminated Displays Division, 18225 N.E. 76 St., Redmond, WA 98052. 206/885-4353. Circle no. 21

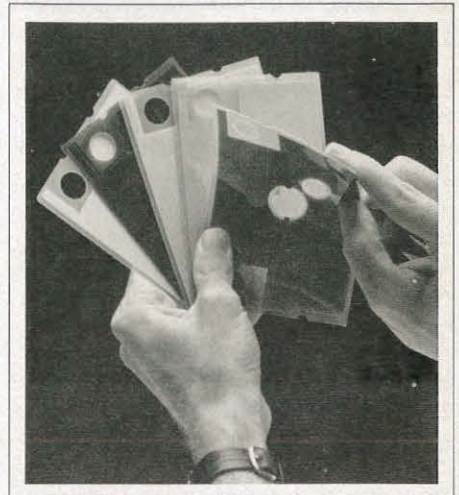

## AD-MU SHIELDING DOES ENHANCE EMI SENSITIVE COLOR DISPLAYS FOR



Achieve high quality hues and sharper color definition for avionics, computer graphics, medical instrumentation, military and other critical color image applications.

A properly selected shielding alloy... placed around or adjacent to a circuit component... suppresses radiated magnetic fields interfering with other nearby components, or vice versa.

That's how AD-MU shielding alloys solve your problem.

56 pages of this 84-page Procurement Catalog/Engineering Manual contains useful technical data covering the entire magnetic shielding field; 28 pages consist of usual catalog type data.

Just request this vital helpful data on your letterhead and it's yours. ➔

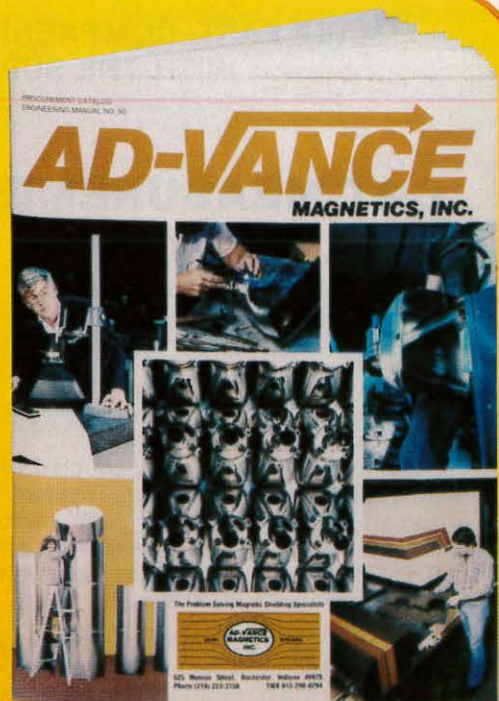

## AD-VANCE MAGNETICS, INC.

625 MONROE STREET, ROCHESTER, INDIANA 46975  
(219) 223-ADMU FAX 219-223-2524

The Problem Solving Magnetic Shielding Specialists—4 Decades of Magnetic Shielding Leadership

Circle no. 22

## new products

### DC-DC converters

Endicott Research Group's E800U and HV Series DC-DC converters provide outputs of from 500 to 1500 VDC at up to 6 W from low dc input voltages. Units can also be tailored to fit specific combinations of input and output voltages. The 1.43 × 1.50 × 1.03 in. converters mount on a standard PC board and have an operating temperature range of 0° to +70°C, 85° max. case temperature standard. The E800U price is \$20.55 ea. at 250 pieces; the E800HV price is \$30.80 ea. at 250 pieces.

For further information contact Michael Foldes or Dan Ward, Endicott Research Group, Inc., 2601 Wayne St., P.O. Box 269, Endicott, NY 13760. 607/754-9187.

Circle no. 23

### Custom LCD modules

Interface Products, Inc., announces a new line of custom LCD modules. Available in almost any configuration up to 7 in.<sup>2</sup>, the small modules are available with alphanumeric or pictorial displays and feature easy user interface, fast-response time, low power, and built-in electronics. The modules are direct-sunlight readable, backlit for total-darkness legibility, and offer removable or interchangeable lighting schemes with high-contrast wide viewing angles, and full-military-operating temperatures. The modules are available in various legend configurations including dot-matrix displays. The LCD modules are designed and engineered for reliability and long life, and meet or exceed the requirements of MIL-E-5400, MIL-STD-704, and MIL-STD-810.



For further information contact William Lang, Interface Products, Inc., 4630 North Ave., Oceanside, CA 92056. 619/945-0230. ■

Circle no. 24

Copies of articles from this publication are now available from the UMI Article Clearinghouse.

Mail to: University Microfilms International  
300 North Zeeb Road, Box 91 Ann Arbor, MI 48106

## MAKE FAST, COMPREHENSIVE, AUTOMATIC CRT MEASUREMENTS WITH THE SUPERSPOT 100 FROM MICROVISION

### CRT MEASUREMENT SYSTEM

The **SUPERSPOT 100** System coupled with the **SPOTSEEKER II** Positioning System (with Automatic Focus) allows fully automatic characterization of Color and Monochrome CRT Displays without operator intervention.

#### Measures:

- Luminance (Footlamberts & Nits) • Line Width, Including Color Line Width (Gaussian Fit) (1 Second)
- Color Misconvergence (2 Seconds) • Linearity, Pincushion and Focus • Line Jitter, Swim and Drift
- Contour Maps of Spots, Lines or Characters (10 Seconds) • Beam Landing & Crowding
- FFT for Discrete Frequency Spectra (1024 points in one second) • High Voltage Regulation Tests
- Real Time Display of Beam Intensity Profile (20 Frames/Second Display) • Disk Data Logging • MTF

#### Provides:

- Pattern Generation for Tests • Adjustable Cursors for Feature Analysis



MICROVISION • 591 West Hamilton Avenue, Suite 250, Campbell, CA 95008 • Tel: 408/374-3158 • FAX: 408/374-9394

Circle no. 25



## October

**Human Factors Society Annual Meeting.** Marian Knowles, Human Factors Society, P.O. Box 1369, Santa Monica, CA, 90406. 213/394-1811.

Oct. 19-23 New York, NY

**Test and Transducer Exhibition.** Show Organizer, Trident International Exhibitions, 21 Plymouth Rd., Tavistock, Devon PL19 8AU, England. 01-822-4671.

Oct. 20-22 London, England

**The Animation Festival Bristol 1987.**

Irene Kotlarz, 41B Hornsey Lane Gardens, London N6 5NY, U.K. 01-341-5015.

Oct. 22-Nov. 1 Bristol, England

**Sixth Annual Pacific Northwest Computer Graphics Conference.**

Paul Katz, Univ. of Oregon Continuation Center, 1553 Moss St. Eugene, OR 97403. 503/686-3537.

Oct. 25-27 Eugene, OR

**Cambridge Symposium on Optics in Medicine and Visual Image Processing.**

SPIE, P.O. Box 10, Bellingham, WA 98227-0010. 206/676-3290.

Oct. 25-30 Cambridge, MA

**Digital Image Processing and Visual Communications Technologies in Meteorology.**

SPIE, P.O. Box 10, Bellingham, WA 98227-0010. 206/676-3290.

Oct. 25-30 Cambridge, MA

**New Directions in Photodynamic**

**Therapy.** SPIE, P.O. Box 10, Bellingham, WA 98227-0010. 206/676-3290.

Oct. 25-30 Cambridge, MA

**Stanford Resources' Fourth International Flat Information Display Conference.**

International Planning Information, 465 Convention Way #1, Redwood City, CA. 415/364-9040.

Oct. 27-28 San Jose, CA

**Third Symposium on Human Interface.**

Prof. Tamura or Prof. Kurokawa, Osaka Univ., 1-1 Machikaneyama-cho, Toyonaka-shi, Osaka, 560, Japan. (06) 844-1151

Oct. 27-29 Osaka, Japan

**National Database and Fourth Generation Language Symposium.**

Mary E. Lownie, Digital Consulting Assoc., Inc., 6 Windsor St., Andover, MA 01810. 617/470-3870.

Oct. 27-30 Dallas, TX

**Computer Communication for Developing Countries '87.**

Dr. P. P. Gupta, CMC Ltd., 1 Ring Rd., Kilokri Opp. Maharani Bagh, New Delhi, India. 631699, 635086, 630827.

Oct. 27-30 New Delhi, India

**The Artificial Intelligence and Advanced Computer Technology Conference and Exhibition.**

Tower Conference Management, 331 W. Wesley St., Wheaton, IL 60187. 312/668-8100.

Oct. 28-30 Atlantic City, NJ

## November

**Advances in Intelligent Robotics Systems and IECON '87 Joint Conference.**

SPIE, P.O. Box 10, Bellingham, WA 98227-0010. 206/676-3290.

Nov. 1-7 Cambridge, MA

**Electronic Imaging '87.**

Richard Murray, Institute for Graphic Communication, 375 Commonwealth Ave., Boston, MA 02115. 617/267-9425.

Nov. 2-5 Boston, MA

**COMDEX/Fall '87.**

The Interface Group, 300 First Ave., Needham, MA 02194. 617/449-6600.

Nov. 2-6 Las Vegas, NV

**INFOTEX.**

The Interface Group, 300 First Ave., Needham, MA 02194. 617/449-6600

Nov. 3-5 Canberra, Australia

**International Plastics and Rubber Exhibition.**

British Information Services, 845 Third Ave., New York, NY 10022. 212/752-8400

Nov. 3-7 Birmingham, England

**Workshop on Workstation Operating Systems.**

Luis-Felipe Cabrera, 6572 Northridge Dr., San Jose, CA 95120. 408/927-1838.

Nov. 5-6 Cambridge, MA

**Cambridge Symposium on Fiber Optics/Integrated Optoelectronics.**

SPIE, P.O. Box 10, Bellingham, WA 98227-0010. 206/676-3290.

Nov. 8-13 Cambridge, MA

**Micro Robots and Teleoperators**

**Workshop.** MRT Workshop, 4B-623, AT&T Bell Labs, Holmdel, NJ 07733.

Nov. 9-11 Cape Cod, MA

**NCGA's Mapping & Geographic Information Systems '87.**

Bob Cramblitt, National Computer Graphics Association, 2722 Merrilee Dr., Suite 200, Fairfax, VA 22031. 703/698-9600.

Nov. 9-12 San Diego, CA

**Photometry and Colorimetry for Information Displays—Short Course.**

UCLA Extension, P.O. Box 24901, Los Angeles, CA 90024. 213/825-1047.

Nov. 9-13 Los Angeles, CA

**Drives/Motors/Controls and Programmable Controllers and Systems Exhibitions.**

British Information Services, 845 Third Ave., New York, NY 10022.

212/752-8400.

Nov. 10-12 Birmingham, England

**International Symposium on the Technologies for Optoelectronics.**

SPIE, P.O. Box 10, Bellingham, WA 98227-0010. 206/676-3290.

Nov. 16-27 Cannes, France

**Computer Peripherals and Small Computer Systems Exhibitions.**

British Information Services, 845 Third Ave., New York, NY 10022. 212/752-8400.

Nov. 17-20 London, England

**International Conference on Information Science and Engineering.**

R. Larry, Institute of Electronic and Radio Engineers, 99 Gower St., London, WC1E 6AZ, U.K.

Nov. 25-27 York, England

**Workshop on Computer Vision.**

Prof. Kang G. Shin, Dept. of EE and Computer Science, Univ. of Michigan, Ann Arbor, MI 48109-1109. 313/763-0391.

Nov. 30-Dec. 2 Miami Beach, FL

# Approaching **ZERO DEFECTS**



## **PEG CRT BULBS**

- Continuous Process Control
- More Uniform Wall Thickness
- 1/2" to 7" Diameter Range
- Low Tooling Cost
- Prototype Design Work
- Better than Machine Made Round CRT Bulbs

**The Leader in Hand-Crafted  
CRT Bulb Blanks**

For details call 609/691-2234.

# PEG

**PRECISION  
ELECTRONIC  
GLASS, INC.**

1013 Hendee Road  
Vineland, NJ 08360

Circle no. 26

32 Information Display 10/87

## calendar

### December

**National Database and Fourth Generation Language Symposium.** Mary E. Lownie, Digital Consulting Assoc., Inc., 6 Windsor St., Andover, MA 01810.

617/470-3870.

Dec. 2-5 Boston, MA

**IEDM: 1987 IEEE International Electron Devices Meeting.** Melissa M. Widerkehr, Courtesy Associates, Inc., 655 15 St. N.W., Suite 300, Washington, DC 20005.

202/347-5900.

Dec. 6-9 Washington, DC

**Lasers '87.** Society for Optical and Quantum Electronics, P.O. Box 245, McLean, VA 22101. 703/642-5758.

Dec. 7-11 Lake Tahoe, NV

**1987 Microcomputer Graphics Conference.** Susan Werlinich, Expoconsul International, 3 Independent Way, Princeton, NJ 08540. 609/987-9400.

Dec. 16-18 New York, NY

**1987 Architects and Engineers Conference.** Carol S. Henderson, Expoconsul International, 3 Independence Way, Princeton, NJ 08540. 609/987-9400.

Dec. 16-18 New York, NY

**Postponement:** Please note that the COMDEX in Japan Conference and Exposition, scheduled for March 1-3, 1988, has been postponed.

### Call for Papers

**The Society for Information Display 1988 International Symposium, Seminar and Exhibition.** May 23-27, Anaheim, CA.

Papers are solicited in the following areas: emissive and non-emissive flat panels; CRT displays; hard copy/printers; display systems and applications; automotive displays; display addressing/packaging; interactive I/O technology; human factors; large-area displays; workstations; and avionic displays. For a copy of the call for papers, contact the Society for Information Display, c/o Palisades Institute for Research Services, Inc., 201 Varick St., Rm. 1140, New York, NY 10014. 212/620-3388.

Deadline for abstracts: Dec. 7

**ISCC/SID Joint Technical Meeting.** May 8-10, Baltimore, MD (jointly sponsored by the Inter-Society Color Council and SID). Papers are solicited in the following areas: accurate color transference between computer/video graphics and electronically generated hard copy; color theory; flat-panel and CRT display color techniques; electronic printer color techniques; standards; human factors of color; color requirements; measurement, characterization, calibration, and viewing of color. Send a 100-word abstract to Lawrence E. Tannas, Jr., 1426 Dana Pl., Orange, CA 92666. 714/633-7874; Fax: 714/633-4174. Deadline for abstracts: Dec. 10

**1988 International Display Research Conference.** Oct. 4-6, San Diego, CA. Papers are solicited for, but not limited to, the following areas: light emitting and non-emissive technologies for direct-view and projection displays; non-impact printing technologies; addressing technology; device reliability; image quality and characterization; and new phenomena and concepts. Emphasis will be placed on research and early development aspects of display technology and related hard-copy and printer technology. For a copy of the call for papers, contact Palisades Institute for Research Services, Inc., Attn.: IDRC, 201 Varick St., Rm. 1140, New York, NY 10014. 212/620-3388.

Deadline for abstracts: May 2

**Lasers '87.** Dec. 7-11, Lake Tahoe, NV. Post-deadline papers will be accepted through Nov. 25. For further information write Lasers '87, Society for Optical and Quantum Electronics, P.O. Box 245, McLean, VA 22101. 703/642-5758. Deadline for abstracts: Nov. 25 ■

*Find it fast in*

### **ID Classified**

- job opportunities
- positions wanted
- consultants
- business opportunities

### Bay Area Chapter

SID's Bay Area Chapter members welcomed **Robert Durbeck** of **IBM Corp.** to their July 23 Chapter meeting. Dr. Durbeck's discussion "The Computer Printer Industry: Overview and Technical Challenges" highlighted electrophotographic, serial-wire-matrix, and ink-jet printer technologies.

### Greater Dayton Chapter

**Lawrence E. Tannas, Jr.**, of **Tannas Electronics** was the guest speaker at the July 30 Greater Dayton Chapter Meeting. Mr. Tannas gave an interesting presentation entitled "Electronic Displays at the Paris Air Show."

### Los Angeles Chapter

The June 24 SID Los Angeles Chapter meeting focused on the "Flat CRT," presented by **Pat Henry** of **Phillips**. The outcome of the meeting was: "The CRT is not dead yet!"

### Minneapolis-St. Paul Chapter

Director **Richard Jamieson** chaired the August 20 meeting of the Minneapolis-St. Paul SID Chapter. Members planned and discussed new programs and officers for the coming year.

### UK and Ireland Chapter

The SID UK and Ireland Chapter is branching out in new and ever widening circles. The newsletter is now produced mainly by means of an Apple IIe P/C and an IBM 3812 page printer. The Chapter is also preparing for its Nov. 10 annual general meeting, which will also highlight CRT displays.

On July 6 and 7, the UK and Ireland Chapter held two sessions on "Color Displays" at the University of Durham. Speakers included **D. Healy, IBM; B. Green, Thorn-EMI; M. Higton, Phosphor Products; P. Phillips, British Aerospace; K. Ruddock, Imperial College; and D. Washington, Philips**. Topics covered market needs, LCDs, EL, flat CRTs, optimizing use of color, and color vision. ■

# STEPPER SAVER



Now there's no need to spend over a million dollars for a stepper. The alternative is the Opti-Beam® 6626 UV Exposure System for 1/5th the cost!

This advanced primary image transfer system provides:

- A large 14" x 14" image area
- 2 Micron registration accuracy
- 5 Micron resolution in proximity
- Video alignment system, 20-200x

You owe it to yourself to step up in technology and down in costs. So, contact us today for more information.



**Optical Radiation Corporation**

Electronic Products Division  
1300 Optical Drive, Azusa, CA 91702  
(818) 969-3344 • TWX 910-584-4851

*Brilliance in advanced technology*

## CALL FOR PAPERS

**ISCC/SID Joint Technical Meeting  
May 8-10, 1988, Baltimore, Maryland**

**Meeting Theme:  
Video to Hard Copy to Video in Color**

The 57th Annual Meeting of the Inter-Society Color Council (ISCC) is planned to be jointly sponsored this year by the Society for Information Display (SID), a member body, with Mr. Nick Hale (ISCC) as Meeting Chairman, and Mr. Lawrence Tannas, Jr. (SID), as Program Chairman.

The meeting will focus on the problems associated with accurately transferring colors from computer graphic and video presentations to electronically generated hard copy, and vice versa, through a video camera or optical scanner. The proliferation of sophisticated computer-aided design on high-resolution color displays and electronic color printers and copiers has made it increasingly desirable, for aesthetic and utilitarian reasons, to transfer colors accurately from one system to another. The problems are compounded by the fact that electronic display images use additive colors and hard copy images use subtractive colors.

Abstracts of 100 words outlining a proposed paper for a 25-minute presentation are solicited on theory, solutions, and problems associated with the meeting theme. The conference is intended to be tutorial in nature and will include theoretical papers as well as state-of-the-art solution papers with demonstrable hardware. Suggested topics include: Color theory; flat-panel and CRT display color techniques; electronic printer color techniques; standards; human factors of color; requirement for color; transfer of color; and measurement, characterization, calibration, and viewing of color.

The technical paper sessions are scheduled for the afternoon of May 9 and day of May 10, with an author interview, hardware demonstration, and poster session in the late afternoon of May 9 and 10. The poster session is being planned for the conference by Ms. Paula Alessi (ACS). Submitted abstracts will automatically be considered for the poster session.

Send abstracts to Lawrence E. Tannas, Jr., 1426 Dana Place, Orange, CA 92666 (Tel. 714/633-7874; Fax: 714/633-4174) on or before December 10, 1987.

## id classified

**Classified ad rates:** \$55/column-inch (min.); \$10/line (for fractions of an inch); \$10/insertion for blind box no. at /D (replies forwarded). **Size:** 1 column-inch = 10 lines (ave. 6 words/line). Large-type all-caps heading (max. 17 characters) takes up 2 lines. Allow 1 line for blind box no. **Deadline:** One month before issue date. **Payment:** Send minimum \$55 payment with order to: Information Display, c/o Palisades Institute, 201 Varick St., Suite 1140, New York, NY 10014. **Questions?** Call 212/620-3371.

### job opportunities

#### Senior Chemist and Electronics Engineer

Research Frontiers Incorporated, a small public company located on Long Island developing products which use orientable suspended particles for the control of light, is seeking highly motivated and talented individuals with degrees in chemistry and electrical engineering. Experience with electrophoretic, electrochromic, or liquid crystal devices would be advantageous.

We offer a congenial and stimulating atmosphere, attractive salary, and opportunity for advancement. Interested individuals and invited to send their resume in confidence to: Regina E. Boerner at Research Frontiers Incorporated, 240 Crossways Park Drive, Woodbury, NY 11797.

### job opportunities

#### Engineering & Sales

We place professionals in the electronics industry. Management/Sales/Engineering/Applications/Etc. Nationwide recruiting and placement—All fees employer paid. Strictest confidence. Call Shannon Smith at ProCounsel 1-800-545-5900.

### consultants

**Howard W. Grossbohlh  
CONSULTANT  
Cathode Ray Tubes  
Cathode Ray Tube Displays  
805-581-1467**

## No Light Wait.

With BKL EL lamps, lead times — and costs — are drastically reduced. KARD-O-LITE, a patented, flexible material, is the key to BKL's revolutionary automated manufacturing process. And the answer to *all* your EL needs.

Cool, flexible and extremely thin (.012" to .018"), BKL's EL lamps are ideal for LCDs, membrane switches, electronic displays, signage, emergency and safety lighting, as well as automotive and aircraft applications.

For more information, call **Dean Smith** at **(215) 277-2910**.

**BKL**

**Bonar KARD-O-LITE, Inc.**  
421 Feheley Drive, King of Prussia, PA 19406

## sustaining members

### A

Ad-Vance Magnetics, Inc.  
AEG Corp.  
Amuneal Manufacturing Corp.  
Applied Films Lab, Inc.

### B

Babcock Display Products  
Ball Electronic Systems Div.  
BDH Ltd.  
Bendix Corp.  
Bidco, Inc.

### C

Cannon, Inc.  
Cardion Electronics  
CELCO  
Cherry Electrical Products Corp.  
Clifton Precision/Special Devices  
Clinton Electronics Corp.  
Computing Devices Co.  
Connector Corp.  
Conrac Corp.  
Corning Glass Works

### D

Dale Electronics  
Data Images  
David Sarnoff Research Center, Inc.  
Digital Electronics Corp.  
Displays Inc.  
DISCOM/Display Components, Inc.

### E

Eagle Magnetic Co., Inc.  
EEV, Inc.  
EG&G Gamma Scientific  
Electronic Display Systems, Inc.  
Electro-Plasma, Inc.  
EM Industries  
Endicott Research Group, Inc.

### F

Ferranti-Packard Electronics, Ltd.  
Futaba Corp.

### G

GEC Avionics, Inc.  
General Atronics Corp.  
General Electric Co.  
GML Information Services  
GTE

### H

George D. Harris Assoc., Inc.  
Hartman Systems  
Hazeltine Corp.  
Hewlett-Packard Co.  
Hitachi, Ltd.  
F. Hoffman La-Roche & Co., Ltd.  
Hoya Optics, Inc.  
Hughes Aircraft Co.  
Hycom, Inc.

### I

IBM Corp.  
Imapro Corp./Imaprint Design, Inc.  
Incom, Inc.  
Industrial Electronic Engineers, Inc.  
Infodex, Inc.  
Interstate Electronics Corp.  
Inter-technical Group, Inc.  
ISE Electronics Corp.

### K

K & R Engineering Sales Corp.  
Kollmorgen Corp. Photo Research Div.

### L

Litton Panelvision Corp.  
Litton Systems Canada Ltd.  
Litton Systems, Inc. (2)  
Los Alamos National Laboratory

### M

Magnavox Government & Industrial  
Electronics Co.  
Magnetic Radiation, Inc.  
Microfield Graphics, Inc.  
Microphase Laboratories  
Microvision  
Minolta Corp.  
Mitsubishi Chemical Industries  
America, Inc.  
Mitsubishi Electronics America, Inc.  
Monitronix Corp.

### N

NEC Electronics, Inc.  
NEC Home Electronics (USA), Inc.  
Norden Div. United Technologies Corp.

### O

OKI Electric Industry Co., Ltd.  
Optical Coating Lab., Inc.  
Optical Radiation Corp.  
Orwin Associates, Inc.  
Ovonic Imaging Systems, Inc.

### P

Penn-Tran Corp.  
Philips Electronics, Ltd.  
Phosphor Products Co., Ltd.  
Photonics Technology  
Planar Systems, Inc.  
Plessey Naval Systems  
Precision Electronic Glass, Inc.  
PTK/Rantec Div. Emerson Electric Co.

### Q

Quantum Data Inc.

### R

Racal Microelectronic Systems  
Rank-Brimar, Ltd.  
Raytheon Co.  
The Report Store  
Ricoh Co., Ltd.  
Rogerson Kratos Corp.

### S

SAI Technology Co.  
Sanders Associates, Inc.  
Schott America—Glass & Scientific  
Products, Inc.  
Sigmatron Nova, Inc.  
Singer-Librascope  
Sony Corp.  
Stanford Resources, Inc.  
Supertex, Inc.  
Syntronic Instruments, Inc.

### T

Taliq Corp.  
Tecknit  
Tektronix, Inc.  
Test & Measurement Systems, Inc.  
Texas Instruments, Inc.  
Thomas Electronics, Inc.  
Thomson Electron Tubes & Devices Corp.

### U

UCE Liquid Crystal Displays  
United Enclosures, Inc.

### V

Venus Scientific, Inc.  
Video Monitors, Inc.  
Visual Information Institute, Inc.

### W

Westinghouse Electric Corp.

### Z

Zenith Electronics Corp.

## index to advertisers



### True Grey Shades at High Speeds for Less than \$5000

Raytheon's TDU-850, Thermal Display Unit, produces photo quality images on an 8 3/4" x 200 ft. roll. The TDU-850 prints 16 shades of grey in less than 20 milliseconds per line; black and white images at 5 milliseconds per line. Price per unit from \$4950, depending on interface and application. (Slightly higher overseas). Discounts for OEM large volume quantities. Fixed thermal head assures perfect registration. Resolution better than 200 dots/inch. Direct thermal technology requires no toners or developers. Standard or custom interfacing. For details, contact **Marketing Department, Raytheon Ocean Systems Company, 1847 West Main Rd., Portsmouth, RI 02871**  
Telephone (401) 847-8000  
Telex 092 7787

# Raytheon

Circle no. 29

	Page
AEG Corp.....	C2
Ad-Vance Magnetics.....	29
Bonar KARD-O-LITE.....	34
CELCO.....	2
Connector Corp.....	27
Hughes Aircraft Co.....	26
Hycom.....	24
ISCC/SID Joint Technical Meeting.....	34
Interface Products.....	4
International High Voltage Electronics.....	28
Microvision.....	30
Minolta Corp.....	25
Optical Radiation Corp.....	33
Panasonic Industrial Co.....	1
Precision Electronic Glass.....	32
Raytheon Ocean Systems Co.....	36
Rohm Corp.....	C4
Thomson Electron Tubes and Devices Corp.....	C3
Westinghouse Electric Corp.....	22, 23

#### Business Office

Palisades Institute for  
Research Services, Inc.  
201 Varick Street, Suite 1140  
New York, NY 10014  
Jay Morreale, Advertising Mgr.  
212/620-3371

#### Sales Office—Western States

Ted Lucas  
P.O. Box 852  
Cedar Glen, CA 92321  
714/337-6627

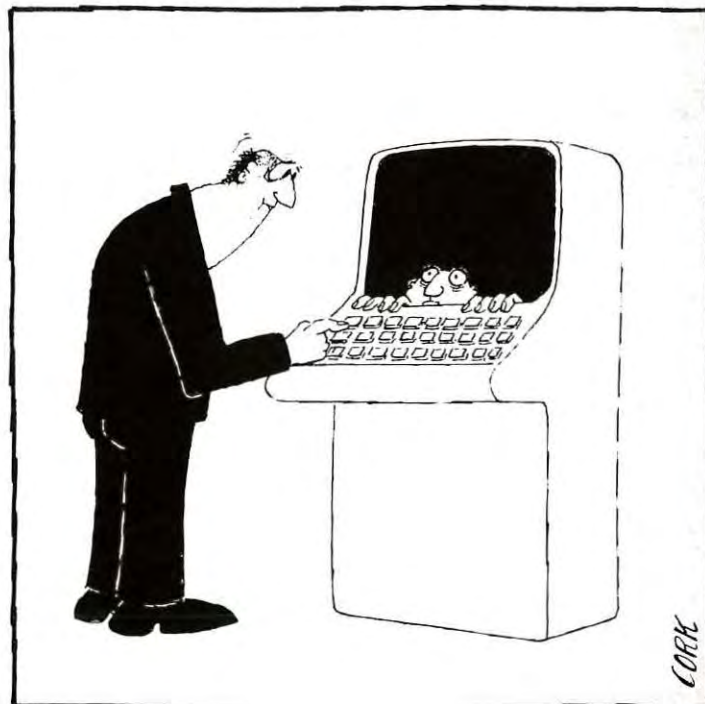

# THOMSON-CSF



## THE FURTHER WE GO, THE FURTHER YOU GO.

Thomson-CSF is your winning partner for professional display tubes and devices. Whether your applications are in radar, avionics, defense, industry or medicine, you can be sure of our technology for reliability and performance, even under the most adverse conditions.

Our vast CRT range incorporates the latest models for video projection, short head-up and head-down displays, helmet-mounted displays, ground/airborne monochrome and color radars, photographic data recording, instrumentation, etc.

And our proven AC plasma panels offer the ultimate in readability and ruggedness for medium and high density graphics display, in all environments.

With manufacturing plants in Europe and the US, we are at hand to let you benefit

Special monitor CRTs including ruggedized color radar and helmet mounted displays



Ac ruggedized display panels. Tireless, flicker-free display. Up to 1,280 x 1,280 dots.



from our quality products with the best customer care. Just as we did for major programs worldwide.

In radio and television, telecommunications, military and civil aviation as well as in a wide range of scientific and medical applications, Thomson-CSF knowhow gets your systems moving. Fast.

**The sharpest image devices in the world.**

Very high definition CRTs. Linewidth as small as 20  $\mu\text{m}$ . Flat optical glass screens of up to 205 mm dia.



Very high brightness projection CRTs. Up to 175,000  $\text{cd m}^{-2}$ . Dispenser cathodes.



**THOMSON ELECTRON TUBES AND DEVICES CORPORATION**  
550 Mount Pleasant Avenue  
P.O. Box 6500  
DOVER, NEW JERSEY 07801.  
Tel.: (201) 328-1400. TWX: 710987 7901.

**Belgique:** BRUXELLES  
Tel. (32-2) 648 64 85  
Tx 23 113 THBXL B

**Italia:** ROMA  
Tel. (39-6) 639 02 48  
Tx 620 683 THOMTE I

**Brazil:** SAO PAULO  
Tel. (55-11) 542 47 22  
Tx (011) 24 226 THCSF BR

**Japan:** TOKYO  
Tel. (81-3) 264 63 46  
Tx 2 324 241 THCSF J

**Canada:** MONTREAL-QUEBEC  
Tel. (1-514) 288 41 48  
Tx 5 560 248 TESAFI MTL

**Sverige:** TYRESÖ  
Tel. (46-8) 742 02 10

**Deutschland:** MÜNCHEN  
Tel. (49-89) 78 79-0  
Tx 522 916 CSF D

**United Kingdom:** BASINGSTOKE  
Tel. (44-256) 29 155  
Tx 858 865 TESAFI G

**España:** MADRID  
Tel. (34-1) 405 16 15  
Tx 46 033 TCCE E

**U.S.A.:** DOVER  
Tel. (1-201) 328 1400  
TWX 710987 7901

**France:** BOULOGNE-BILLANCOURT  
Tel. (33-1) 46 04 81 75  
Tx THOMTUB 200 772 F

Circle no. 30

# Put your Page Printer on the LEDing edge

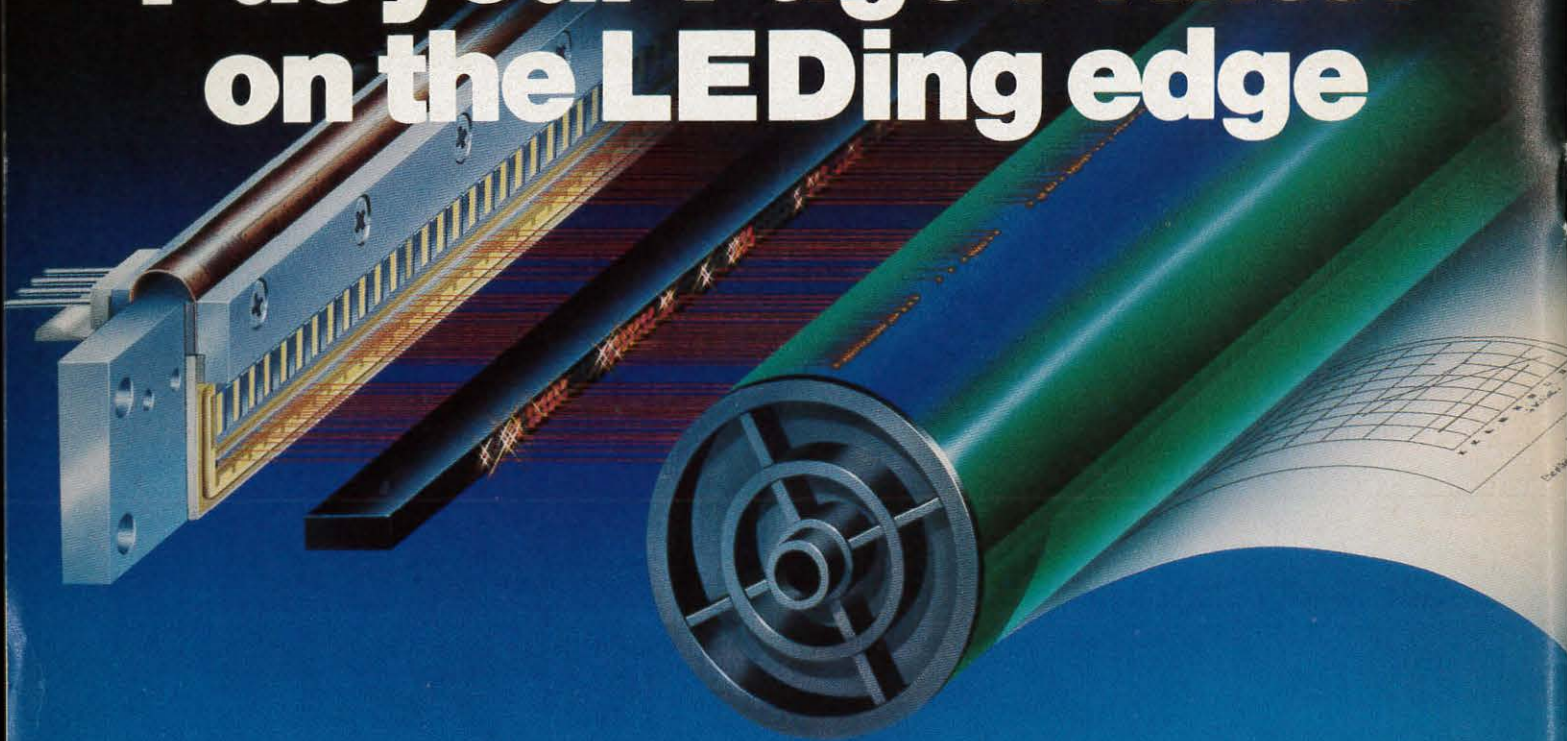

Build our lead in LED printheads into your next page printer. Make it smaller and more compact. Make it insensitive to vibration. Give it consistent spot shape, resolution to 480 dpi and print widths to 12". Make it less complex without moving parts for imaging. Make it require less maintenance. Give it longer life.

Laser technology is no longer acceptable for new page printer designs. Tomorrow's medium- and high-speed page printers are using ROHM LED printheads. ROHM is already the world's number one supplier. And, it's easy to see why. ROHM printhead technology — our combined experience in optoelectronic and integrated circuits — really shows. In performance claims you can believe. With quality you can see. Reliability you can depend on. It's there thanks to rigid control of raw materials, automated manufacturing techniques, strict adherence to statistical process controls and our dedicated people.

For the complete story, call (714) 855-2131. Outside California, dial 1-800-854-3386, ask for

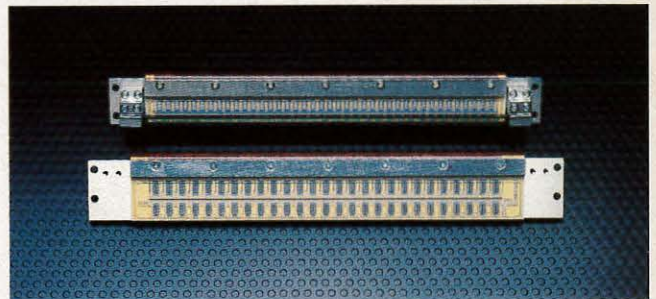

*GaAsP LED arrays improve registration by focusing each element at a specific location. Integrally mounted shift register/driver ICs (nitrogen sealed) reduce size and enhance reliability. Wavelength: 660nm. Light output: 4.5uW/st @ 5mA. Compatible with amorphous silicon, organic and selenium photoconductor technologies.*

Ext. 16. TWX: 910-595-1721. FAX: 714-855-1669.  
Write ROHM CORPORATION, P.O. Box 19515,  
Irvine, CA 92713 or return the attached  
postage-paid reply card.

## ROHM

Circle no. 31